

# Table of Contents

- 1. Travelled Surfaces
  - 1.1 Roads
  - 1.2 Sidewalks
- 2. Stormwater Design
  - 2.1 Storm Sewers
  - 2.2 Stormwater Pumping Station Design
- 3. Street Lighting (CK Special Provisions)
  - 3.1 General
  - 3.2 Luminaires
  - 3.3 Poles
  - 3.4 Arms
  - 3.5 Power Distribution
  - 3.6 Other Services
  - 3.7 Illumination Standard – Street and Roadway Lighting
  - 3.8 Light Intensity Standards
  - 3.9 Techniques to Implement Lighting Guiding Principles
  - 3.10 Submission Requirements for Outdoor Lighting
  - 3.11 Guidelines for Structure Lighting
  - 3.12 Definitions
  - 3.13 Backfill and Compaction
  - 3.14 Restoration and Landscaping
  - 3.15 Recycled Material
  - 3.16 Other Utilities

## FIGURES

Figure CS-1 to Figure CS-6

Figure D-1 to Figure D-4

Figure E-1 to Figure E-6

Figure L-1 to Figure L-10

Figure S-1 to Figure S-7

Typical Road Cross-Sections

Entrances

Luminaire Details

Sewer and Service Systems and Utilities

Manholes, Catch Basins, Sidewalks, Curb & Gutter

## **SPECIFICATIONS AND PROVISIONS**

---

### **1.0 TRAVELLED SURFACES**

#### **1.1 Roads**

Granular base requirements are to be determined through geotechnical investigation and report.

Granular 'A' materials shall meet the minimum requirements of OPSS 1010 and shall be compacted to a minimum 100 percent of the Standard Proctor maximum dry density.

Recycled material can be used as road base (meeting OPSS 1010) up to 300 mm below asphalt where crushed limestone (non-recycled material) Gran-A shall be used.

Asphaltic concrete mixes shall consist of PG 58-28 asphalt cement conforming to OPSS 1101, fine and coarse aggregates conforming to OPSS 1003 and recycled asphalt pavements (RAP). The use of RAP in the final product should not exceed 15% for surface course asphaltic concrete and 20% for binder course asphaltic concrete.

A qualified materials testing company shall be retained by the Contractor to design the asphalt mixes, which will be submitted to Chatham-Kent for review. The use of recycled asphalt in the final product shall not exceed 15 percent.

#### **Other Pavements**

Other pavements such as concrete pavements shall be designed on the basis of a geotechnical investigation. Pavements shall be designed to provide adequate drainage of stormwater runoff as well as drainage of the granular road base. Accordingly, the following minimum standards shall apply:

#### **Subdrains with Filter Sock**

- 100 mm diameter polyethylene pipe to OPSS 1840 and CGSB with filter fabric and a minimum stiffness factor of 300 kPa for all roads, at Chatham-Kent's discretion, 100 mm diameter heavy-duty perforated Big 'O' may be acceptable if installed with grade stakes or laser level
- Constructed continuous along the back of curbs at a gradient equal to the longitudinal pavement slope (or minimum 0.30 percent)
- Connected to roadway catch basins or other appropriate outlet

#### **Curb-Inlet Catch Basins**

- OPSD 610.030
- Curb inlet catch basins must have frame and grate for residential/local roads, arterial roads and collectors do not require grate (open)
- Placed at intersections for proper drainage
- Spacing for road drainage no more than 383 m<sup>2</sup> asphalt catchment area per catch basin
- Regular catch basins (OPSD 705.010) to be used where curb inlets are obstructed from installation

#### **Longitudinal Grade**

- Desirable minimum 0.4%
- Absolute minimum at curb returns and cul-de-sacs 0.5%

## SPECIFICATIONS AND PROVISIONS

---

- Maximum 5.0%

### Crossfall

- 3% for sub-base
- 2% for surface

### In intersection areas and cul-de-sacs

- Desirable Minimum 1.0%
- Absolute Minimum 0.6%

### Concrete Curbs and Gutters

- OPSD 600.040 (Collector, Arterial & Local)
- OPSD 600.100 (Local Roads)
- Chatham-Kent Mountable Curb Standard (**See Figure S-6 in Appendix B - “Design Drawings, Figures & Details.”**)

## 1.2 Sidewalks

### Standard:

- Minimum Width 1.5 m or 1.8 m against curb (for local roads only) Minimum Thickness 125 mm, unless otherwise specified by the Municipality
- Base Material 125 mm of Granular ‘A’

### Through Residential Driveway:

- Width 1.5 m
- Minimum Thickness 150 mm
- Base Material 150 mm of Granular ‘A’

### Through Commercial, Industrial, Institutional Entrance:

- Width 1.5 m
- Minimum Thickness 200 mm
- Base Material 200 mm of Granular ‘A’

**Table 1: Concrete Sidewalks**

Cement Type	Portland Cement
Class of Concrete	32 MPa at 28 Days
Class of Exposure	C-2
Class of Aggregate	19 mm nominal size maximum
Air Content	6.5 ± 1.5%
Slump at point of discharge	80 mm ± 30 mm
Maximum water/cementing materials ratio	0.45

## SPECIFICATIONS AND PROVISIONS

---

All sidewalks shall be constructed and clearly delineated through driveways. There are to be no trowel joints, only sawcuts spaced at 1.5 metres. At any intersection, concrete sidewalk ramps and asphalt multi use pathways ramps shall comply with O.P.S.D 310.030, the Figures **D-1 to D-4** of **Appendix B – “Design Drawings, Figures & Details”**, and ensure it meets all Accessibility standards (AODA). Excavation for sidewalk installations is to be included in this work. Cut areas will be graded to uniform cross-section prior to placing concrete (Lower sidewalks across driveway entrances as per OPSD 310.050 as required to achieve entrance grade no greater than 8%). Concrete sidewalks shall not be installed until completion of all electrical and other utility services.

Where required the Contractor shall construct sidewalks at driveways one half at a time. The remaining portion of the sidewalk at the driveway entrance shall be constructed no sooner than four (4) days after the original pour. Openings left for entrances shall be sufficiently wide to allow vehicles to safely enter and exit the property to the satisfaction to the Contract Administrator.

Where possible, consideration shall be given to combine the placement of new curbs, driveways and sidewalks at each driveway so that they can be completed all at once to limit the number of times access is restricted to properties and businesses. No additional payment will be made for remobilization costs to return to the site based on the above noted conditions.

All sidewalk abutting retaining curb and existing buildings shall have expansion joint filler ASTM D1751.

The Contractor shall be responsible for the protection of the concrete surfaces against vandalism or temperature changes that may occur during the curing period. Any deficiencies, graffiti, etc. will be removed and replaced at the Contractor's expense.

All construction joints shall be constructed using full-depth, premoulded joint filler and shall be spaced 4.5 m apart.

The ready mix supplier must certify that the plant, trucks and materials conform to CSA A23.1.

Supply test certificates in accordance with appropriate specifications for concrete. Provide mix designs for concrete at least two weeks prior to use.

Yellow polymer tactile plate installations shall be as per OPSD 310.033 and OPSD 310.039.

The Accessibility for Ontarians with Disabilities Act (AODA) was established in 2005 outlining accessibility standards for organizations, including Municipalities. Ontario Regulation 119/11, Accessibility for Ontarians with Disabilities Act (AODA), was amended by Ontario Regulation 413/12 to include Part IV.1, Design of Public Space Standards (Accessibility Standards for the Built Environment). The amendment to the regulation came into force January 1, 2013 and applies to public spaces that are newly constructed or redeveloped after January 1, 2016 by municipalities among other obligated organizations.

In order to comply with the Act requirements, the exterior path must have a minimum clear width of 1500 mm. Width of 1500 mm is a minimum, wider sections may be required against curb and in special zones including: schools, parks, and commercial business areas.

## SPECIFICATIONS AND PROVISIONS

---

This width can be reduced to 1200 mm to serve as a turning space where the exterior path connects with a curb ramp. Where the curb ramp is provided at a pedestrian crossing, it must have tactile walking surface indicators that:

- a) have raised tactile profiles
- b) have a high tonal contrast with the adjacent surface
- c) are located at the bottom of the curb ramp
- d) are set back between 150 mm and 200 mm from the curb edge
- e) extend the full width of the curb ramp
- f) are a minimum of 610 mm in depth from road pavement edge

Owners will be responsible to maintain and repair damaged sidewalks, for one year from Chatham-Kent's "acceptance of services". The Owner shall also include sidewalks shown on the lot grading sheets submitted to Chatham-Kent, prior to the issuance of building permits.

### 1.2.1 Multi-Use Pathways

Minimum width 3.0 m multi-use pathways may be requested in lieu of or in addition to concrete sidewalks as identified in the Trails Master Plan. The granular base is to be 150 mm minimum wider than the asphalt on each side. Multi-use pathways shall follow side-walk standards for all driveways (maintaining 3.0 m width).

**Table 2: Multi-Use Pathways**

Path Type	Granular 'A' Base Thickness	Granular 'A' Base Width	Base Asphalt	Surface Asphalt
3 m multi-use	250 mm	3.3 m	40 mm HL4	40 mm HL3

## 2.0 Stormwater Design

### 2.1 Storm Sewers

Note: Pipe class to be confirmed by the Engineer based on trench transition widths.

Class 'B' bedding and cover material shall be Granular "A", compacted to 98 percent of the Standard Proctor Maximum Dry Density, to the dimensions detailed on the Contract Drawings. The bedding should extend from about 150 mm below the sewer pipe to at least 300 mm above the pipe.

The Contractor shall perform leakage testing after construction (new installation where there are no existing connections) in accordance with OPSS Form 410 and as directed by the Contract Administrator, method(s) of leakage testing will be determined at time of testing based on field conditions of installation. Contractor shall perform CCTV video for main connections.

Deficiencies identified through the CCTV may require additional testing such as a mandrill test as per the Municipality's request at the Owners expense.

## **SPECIFICATIONS AND PROVISIONS**

---

The Contractor shall also remove and dispose or relocate the existing storm sewer and culverts directly conflicting with the sewer alignment under 300mm in diameter and as noted on the Contract Drawings. Sewers greater than 300 mm diameters are to be done under the sewer removal item.

### **2.2 Stormwater Pumping Station Design**

Wet well submersible pump stations shall also be designed in accordance with Ministry of Environment Specification No.3 – Standard Specification for Submersible Sewage Pumps – Issue No. 2 – March 1984 and specifications herein. The specifications herein will supersede the MECP guidelines should there be any contradictions between the two documents.

All pump stations shall be fitted with an external electrical weatherproof plug for connection of a mobile emergency standby electrical generator in a manner suitable to and approved by the Municipality.

Permanent emergency standby electrical generator facilities shall be provided in all cases where flooding and backup of sewage into private buildings can occur and where the uses of mobile emergency standby electrical generators are not practical or desired by the Municipality.

The need and type of emergency standby power shall be reviewed with the Municipality and MECP Regional Staff early in the design stage.

The sewage retention period shall be adequate to allow for transportation time and shall not be less than 4 hours under average daily flow rates plus infiltration.

One or more pumps capable of pumping the peak design flow with an additional stand-by pump (this is known as firm capacity).

System head calculations shall be undertaken in accordance with MECP Guidelines for Design of Sanitary Sewage Systems and MECP Specification No. 3 as noted herein and per the following:

- Hazen-Williams Coefficient of  $C=120$  for low water level,  $C=130$  for median water Level and  $C = 140$  for high water level conditions
- Minimum force main velocity of 0.76 meters per second (2.5 feet per second)
- Maximum force main velocity of 2.3 meters per second (7.5 feet per second)
- Minimum pump cycle time of 10 minutes

Pump manufacturers must be approved by the Municipality on a case by case basis in order to suit specific circumstances.

All pumping stations shall be fitted with electrical service and components that are site specific and to be approved by the Municipality.

## SPECIFICATIONS AND PROVISIONS

---

### 3.0 **STREET LIGHTING (CK SPECIAL PROVISIONS)**

#### 3.1 **General**

OPSS Form 604, 609, 617, 2428, 2432, 2485 and OPSD 2420.01 shall apply and govern except as amended or extended herein. All electrical work shall adhere to ESA regulations, and Ontario Electrical Safety Code at all times.

#### 3.2 **Luminaires**

The Contractor shall supply and install LED luminaires for street lighting as per the Contract Drawings.

Luminaires shall meet current Entegrus (Chatham-Kent Local Distribution Company) standards for Cobra Head LED street lights. The Contractor shall contact Entegrus to obtain current material specifications for LED luminaire housings and LED lamp ratings and distribution pattern for street lighting.

Note: If proposed development is located within Hydro One jurisdiction, coordination with Hydro One must be completed in order to comply with Hydro One requirements.

##### 3.2.1 **Street Lighting Luminaires – Light Emitting Diode (LED)**

Standard

- Cobrahead style with 39W, 47W, 58W or 98W LEDs as required providing adequate illumination<sup>1</sup>, Type II Max throw, distribution, with glass lens. The luminaire driver current will be based upon the design fixture selected, with a 4000K colour temperature for residential/minor collector and industrial streets and 5000K colour temperature for major collector and arterial streets (as defined in RP-8, latest revision), complete with NEMA or 7-pin photocell receptacle and control. Assembly to come with 120V driver or otherwise to suit site conditions. Colour to match the pole noted below. General Electric Evolve LED Fixture Series Luminaire. Catalogue number ERL1005A340AGRAYILR (1006B, 1007A, 10011A). Refer to **Figures E-1 to E-6 – Appendix B – “Design Drawings, Figures & Details”**.
- Cobrahead style with 39W, 47W, 58W or 98W LEDs as required providing adequate illumination<sup>1</sup>, ANZ high distribution, with glass lens. The luminaire driver current will be based upon the design fixture selected, with a 4000K colour temperature for residential/minor collector and industrial cul-de-sacs (as defined in RP-8, latest revision), complete with NEMA or 7-pin photocell receptacle and control. Assembly to come with 120V driver or otherwise to suit its site conditions. Colour of the luminaire to match the pole noted below. General Electric Evolve LED Fixture Series Luminaire. Catalogue number ERL1005A340AGRAYILR (1006B, 1007A, 10011A). Refer to **Figures E-1 to E-6 – Appendix B – “Design Drawings, Figures & Details”**.

Decorative – Acrylic Option

- Acorn style, 100W solid state LED source or as otherwise required to provide adequate illumination<sup>1</sup>, with refractive array acrylic rippled globe, Type III4 distribution, 1063 series,

## SPECIFICATIONS AND PROVISIONS

---

4000K, pole capital, solid spun aluminum top and NEMA twistlock receptacle and photocell control. Assembly to come with 120V driver or otherwise to suit site conditions. Colour to match the pole noted below. King Luminaire, Washington series “K118R” luminaire. Catalogue number K118R- xxAR-III-100(SSL). Refer to **Figures E-1 to E-6 - Appendix B – “Design Drawings, Figures & Details”**.

- Acorn style, 100W (525mA) solid state LED source or as otherwise required to provide adequate illumination<sup>1</sup>, with clear prismatic acrylic refractor, Type III4 asymmetric distribution, 4000K colour temperature, standard finial, top acrylic reflector & cap and NEMA twistlock receptacle and DTL twistlock photocell control. Modern style swing open housing. Assembly to come with auto-sensing 120V driver or otherwise to suit site conditions. Colour to match the pole noted below. Holophane, Washington series “Postlite II LED Utility” luminaire. Catalogue number AWDE2-P50-40K. Refer to **Figures E-1 to E-6 - Appendix B – “Design Drawings, Figures & Details”**.

### Decorative –Polycarbonate Option

- Acorn style, 100W solid state LED source or as otherwise required to provide adequate illumination<sup>1</sup>, with refractive array polycarbonate rippled globe, Type III4 distribution, 1063 series, 4000K, pole capital, solid spun aluminum top and NEMA twistlock receptacle and photocell control. Assembly to come with 120V drive or otherwise to suit site conditions. Colour to match the pole note below. King Luminaire, Washington series, “K118” luminaire. Catalogue number K118R-PR- III-100(SSL). Refer to **Figures E-1 to E-6 – Appendix B – “Design Drawings, Figures & Details”**.

### Decorative - Glass Option

- Acorn style, 100W (525mA) solid state LED source or as otherwise required to provide adequate illumination<sup>1</sup>, with clear prismatic glass refractor, Type III4 asymmetric distribution, 4000K colour temperature, spike aluminum finial, shorewood style cover and NEMA twistlock receptacle and DTL twistlock photocell control. Modern style swing open housing. Assembly to come with auto-sensing 120V driver or otherwise to suit site conditions. Colour to match the pole noted below. Holophane, Utility Washington series “Postlite LED” luminaire. Catalogue number WAUE2-P50-40K. Refer to **Figures E-1 to E-6 - Appendix B – “Design Drawings, Figures & Details”**.

### 3.2.2 Housing and Finish:

- Single piece unit primarily constructed of A360 aluminum alloy (or better), die-cast or extruded. Die-cast is preferred.
- Shall be designed to eliminate emission of noise from wind and to resist build-up of icicles.
- CSA or cUL rated for wet locations.



## SPECIFICATIONS AND PROVISIONS

---

- Vibration resistant – 3G vibration rating is required. Testing should meet the requirements of ANSI C136.31; however, the test shall be conducted in all three axes with the same luminaire.
- Finish shall be powder coat or equivalent. The nominal thickness of the powder coat shall be at least 2-3 mils. Finish colour shall be grey; however, alternate standard colours, such as bronze and black, shall be available at no extra cost.
- The luminaire shall have a casting designed to accept a NEMA 7 pin locking photocell receptacle in accordance with ANSI C136.41.
- Housing must have undertaken over 1,000 hours of salt spray exposure in accordance with ASTM B117 with no visible abnormalities on the tested parts.
- Wiring and grounding, latching and hinging, mounting shall meet requirements of ANSI C136.37.

### 3.2.3 Mounting:

Luminaires shall be installed onto 2.4 m tapered elliptical aluminium street lighting bracket shall conform to OPSS 2428, Sentinel Pole and Traffic Equipment number RE8MA or approved alternative. The bracket shall be set perpendicular to the through edge of travelled roadway lanes unless otherwise shown on the Contract Drawings. The bracket shall be mounted with a 16 mm galvanized machine bolt, square washer and nut on the top of the pole plate and with 16 mm stainless steel strapping around the bottom of the pole plate.

The Contractor shall drill a pole-wiring aperture (20 mm Dia.) at 225 mm below the top of the pole. A bolt aperture shall be similarly drilled. Apertures shall be de-burred, touched up with zinc rich paint. Wiring apertures shall be fitted with rubber grommets.

Luminaires will be mounted horizontally on a standard style pole and shall be designed to attach to the mounting requirements of Appendix A Item # 3 on a pole via bolted connector. The connector shall use up to four (4) bolts, or equivalent, and shall allow for a vertical tilt adjustment of  $\pm 5^\circ$ .

In the event that post-top lighting exists, an optional adaptation from a 4-inch vertical tenon in compliance with the mounting requirements of Appendix A Item #3 to a horizontal mounting (post-top to cobrahead light) is preferred

### 3.2.4 Weight

Luminaires shall not weigh more than 15 kg and maximum EPA of 0.1 m2.

### 3.2.5 Labeling

Shall have waterproof printed product label with full ratings located inside the housing.

## SPECIFICATIONS AND PROVISIONS

---

Shall have waterproof NEMA wattage rating label meeting ANSI C136.15-2011 located outside the cover and visible from the ground.

### 3.2.6 Optical Assembly

It is preferred that circuiting be designed so individual LED failures will not impact the operation of the other LEDs. No parts shall be constructed out of polycarbonate or any other synthetic material (unless it can be proved it is UV stabilized). Lens discoloration at any point in the warranty period shall be considered a product failure. Optical system shall be rated IP66 or better.

The output of each LED luminaire shall be as shown on the Contract Drawings as an equivalent High Pressure Sodium wattage.

**Table 3: LED Output**

4,000-5,000 lumens LED	100W HPS
7,000-8,500 lumens LED	150W HPS
8,500-11,500 lumens LED	200W HPS
11,500-14,000 lumens LED	250W HPS

Luminaire shall be able to operate normally in:

- Ambient temperatures from +40°C to -40°C;
- Winds up to 160kph;
- Driving rain;
- Snow and sleet; and
- Fog.

#### **Light Loss Factor (LLF) where $LLF = LLD \times LDD \times LATF$ , and**

- Lamp lumen depreciation (LLD) shall be determined by the manufacturer and be based on the percentage of initial output at 88,000 operating hours calculated in accordance with IESNA LM-80 and TM-21. The TM-21 extrapolation can however be up to 14 times.
- Luminaire dirt depreciation (LDD) = 0.90, per IES DG-4 for an enclosed and gasketed roadway luminaire installed in an environment with less than 150 µg/m<sup>3</sup> airborne particulate matter and cleaned every ten years.
- Luminaire ambient temperature factor (LATF) = 1

## SPECIFICATIONS AND PROVISIONS

---

### 3.2.7 Photocell

- Photocell shall be provided with luminaire and included in the total luminaire cost.
- Minimum 20-year rated life.
- Minimum 10-year unconditional manufacturer's warranty.

### 3.2.8 Safety Testing

- Luminaire shall have locality-appropriate governing mark and certification (CSA or CUL).
- Luminaire shall meet the performance requirements specified in ANSI C136.2 for dielectric withstand, using the DC test level and configuration. (In draft – release of ANSI C136.2-2015 anticipated to be soon.)

### 3.2.9 Product Optical Performance

- Luminaire shall be optically efficient. The optical performance of luminaires for given roadway scenarios defined
- Correlated colour temperature (CCT) shall be nominal 4000K
- Colour rendering index (CRI) shall be minimum 70.
- Light distribution shall come in IESNA Type 2 or 3, with optional Type 4 and 5 at no extra cost.
- BUG ratings of B2-U0 or less; however, U0 is mandatory. BUG Ratings shall be in accordance with IES TM-15-11.
- Luminaires shall not exceed unit power density (UPD), calculated per CSA C653:
  1. 0.25 W/m<sup>2</sup> for low pedestrian activity levels.
  2. 0.35 W/m<sup>2</sup> for medium pedestrian activity levels.
- Light engine must be field replaceable/upgradeable without the use of tools.

### 3.2.10 Product Reliability

MTBF data in accordance with Telcordia SR-332 standard shall not be less than 3M hours reported at 25°C (test report must be provided).

Reliability will be evaluated based on the formula  $\text{Reliability} = e^{-\text{time}/\text{MTBF}}$ , where time and MTBF are expressed in hours in order to compare the expected number of failures from one manufacturer to another. Please note that MTBF is only used for the luminaire's useful life. If a proponent's luminaire is rated for only 50,000 hours, MTBF will apply from 0 to 50,000 hours, where at 50,000 hours a maintenance issue is inevitable. It is preferred that the useful life of the luminaire be 88,000 hours; therefore, any lower offering will result in a disqualification

### 3.2.11 Warranty

Proposals submitted shall include a warranty for products and services that the Proponent agrees to maintain throughout the duration if awarded a contract. Proposals which demonstrate

## SPECIFICATIONS AND PROVISIONS

---

an ability to provide a longer and more inclusive warranty on all materials (including LED and drivers) and services will be preferred and receive a higher rating. Proponents may submit their standard warranty provisions with optional provisions for more or less warranty coverage in their proposal. Proponents are to indicate if the warranty is secured through a surety product, and if that option is available.

It is expected that the warranty will include, but is not limited to, the following:

1. It is preferred that luminaire subcomponents such as the LED light engine and Power Supply be modular and replaceable without the need of any tools. It is anticipated that a full component replacement of the luminaire due to any failure be provided. The inability of a luminaire to operate within specifications is, without limitation to other types of failure, considered a failure.
2. Replacement of defective material(s) for a period of ten years from date of installation.
3. Replacement material will be supplied within thirty days of notification. The defective material will be made available to the Proponent by the City. All packaging, shipping costs and arrangements will be borne by the Proponent, delivered duty paid (DDP – Incoterms 2010). The City will remove the defective material(s) and re-install the replacement material(s) at their own expense.

Defective Goods: Goods found to be defective will be quarantined on location. Once the Proponent has been notified of the quarantine, all shipments of goods potentially affected by the defect will cease until the cause of the defect has been remedied as determined by the City.

### 3.3 Poles

#### Standard

- Aluminum round symmetrically tapered shaft, direct buried style, rotary spun polished, suitable for a standard elliptical arm. Overall pole length shall be 30'-0". Aluminous catalogue number RTAP25-745C-DB. Refer to **Figures E-1 to E-6 – Appendix B – “Design Drawings, Figures & Details”**.
- Aluminum round symmetrically tapered shaft, direct buried style, rotary spun polished, suitable for a standard elliptical arm. Above ground style. Overall pole length shall be 25'-0". Aluminous catalogue number RTAP25-745C-AB267. Refer to **Figures E-1 to E-6 – Appendix B – “Design Drawings, Figures & Details”**.

#### Decorative

- Class A (light duty), prestressed concrete, octagonal symmetrically straight shaft with flared base, direct buried style, polished “midnight lace” finish complete with a 35” outside diameter tenon and 40” height. Pole length above finished grade shall be 18'-0”. Stresscrete catalogue number KBH18-E10-DB-140-35/40. Refer to **Figures E-1 to E-6 – Appendix B – “Design Drawings, Figures & Details”**.
- Class A (light duty), prestressed concrete, octagonal symmetrically straight shaft with flared base, direct buried style, polished “Eclipse Black” finish complete with a 35” outside diameter tenon and 40” height. Pole length above finished grade shall be 18'0”.

## SPECIFICATIONS AND PROVISIONS

---

Stressecrete catalogue number KBH18-E11-DB-140-35/40. Refer to **Figures E-1 to E-6 – Appendix B – “Design Drawings, Figures & Details”**.

### 3.4 Arms

Standard

- Side mounted tapered elliptical aluminum arm. Overall arm length shall be 4'-0" or as otherwise required to suit the application, and approved by the Municipality of Chatham-Kent. Refer to **Figure E-08 – Appendix B – “Design Drawings, Figures & Details”**.

### 3.5 Power Distribution

The power distribution system consisting of the primary and secondary power feeders, transformers and underground infrastructure shall be designed in accordance with the appropriate power supply authority requirements. The Owner is responsible to obtain the approval of the appropriate power supply authority prior to construction.

#### 3.5.1 Driver

- At full load, power factor shall be 0.90 (lagging) or better.
- Operating voltage – Power supplies shall operate from 120V-240V, 60 Hz or 347V-480V, 60 Hz as defined.
- Voltage fluctuation tolerance shall be  $\pm 10\%$ .
- Dimming control signal shall be industry standard 0-10 volts DC (IEC 60929).
- Driver current – The driver current options shall be a full range of ratings. It is preferred that the driver current be less than 700mA unless it can be proven that driver with higher driver currents can meet the mean-time-between-failure (MTBF) requirements defined.
- Nominal luminaire input wattage shall account for nominal applied voltage and any reduction in driver efficiency due to sub-optimal driver loading.
- Driver shall be rated for wet locations if installed in IP66 rated housing. If not installed in IP66 rated housing, the driver shall have an IP66 rating.
- Shall be RoHS compliant.
- It is preferred that the driver be field replaceable/upgradeable without the use of tools.
- It is preferred that capacitors utilized in the power supply have a rated life of over 88,000 hours at 85°C.

#### 3.5.2 Electrical Immunity (Surge Protection)

- Stand-alone (easy to be replaced) surge protection device.
- Surge protection is compliant with IEEE/ANSI C62.41, Category C-High 20kV/10kA and in compliance with Appendix D of the DoE MSSLC Model Specification for LED Luminaires,

## **SPECIFICATIONS AND PROVISIONS**

---

which is a luminaire-level surge test spec with multiple strikes, phase angles, and polarities for the surge test protocol.

- It is preferred that the surge module be field replaceable/upgradeable without the use of tools.

### **3.5.3 Radio Frequency Interference**

- Power supplies shall meet FCC 47 CFR Part 15 Interference Requirements.

### **3.5.4 Total Harmonic Distortion**

- Total harmonic distortion shall be less than 15% and shall be recorded at 120V/60Hz input conditions.

### **3.5.5 Thermal Management**

- Shall consist of heat sink fins integrated within the housing with no fans, pumps, or any moving parts and/or liquids, and shall be resistant to debris build-up and bird droppings.
- The heat sink system shall be designed to maintain a junction temperature for the LEDs such that the light engine shall achieve a minimum lifespan of 88,000 hours (IESNA LM-80/TM-21) at 20 degrees C.
- Luminaire shall start and operate in the ambient temperature range of +40°C and -40°C.
- Maximum rated case temperature of driver and other internal components shall not be exceeded when luminaire is operated in ambient temperature range specified.

### **3.5.6 Controls**

- Luminaires shall have 7 pin NEMA ANSI C136.41-2013 standard receptacle and shorting cap. Receptacle shall be wired for adaptive controls.

### **3.5.7 Power Terminals**

- Shall meet ANSI C136.37.
- Shall be sized to terminate #14 to #6 AWG copper or aluminum wire.
- Shall be located inside the luminaire housing.

## **3.6 Other Services**

Other services such as, but not limited to, voice, data and television shall be coordinated by the Designer unless otherwise advised. These services and associated conduit routing shall be clearly identified in road crossings, on cross-sections, etc.

## **3.7 Illumination Standard – Street and Roadway Lighting**

Based on the type and function of the roadway as identified by the Municipality of Chatham-Kent, the following illumination level guidelines will apply for illumination within public right-of-ways.

## SPECIFICATIONS AND PROVISIONS

The following table should be used for streets and roadways of pedestrian areas or that are curved. Otherwise, **Table 4** below, reproduced from RP-8-14, will be used to evaluate straight segments of roadways and streets. The street and roadway classifications of **Table 5** are as per the road classifications of RP-8.

**Table 4: Illumination Standards - Street and Roadway Lighting, Illuminance**

	Street Classification	Illumination Maintained Averaged		Uniformity Ratio Average/Max
		Lux	Ft Candles	
1	Arterial	20	2.0	3.0
2	Major Collector	15	1.5	3.0
3	Residential or Minor Collector	5	0.5	6.0
4	Industrial	5	0.5	6.0

**Table 5: Street and Roadway Lighting, Luminance Method**

Street Classification	Pedestrian Area Classification	Average Luminance $L_{avg}/(Cd/m^2)$ Column 1	Average Uniformity Ratio $L_{avg}/L_{min}$	Max. Uniformity Ratio $L_{max}/L_{min}$	Max. Veiling Ratio $L_{Vmax}/L_{avg}$
	High <sup>1</sup>	1.2	3.0	5.0	0.3
	Medium <sup>1</sup>	0.9	3.0	5.0	0.3
	Low <sup>1</sup>	0.6	3.5	6.0	0.3
Collector <sup>2</sup>	High <sup>1</sup>	0.8	3.0	5.0	0.4
	Medium <sup>1</sup>	0.6	3.5	6.0	0.4
	Low <sup>1</sup>	0.4	4.0	8.0	0.4
Local <sup>2</sup>	High <sup>1</sup>	0.6	6.0	10.0	0.4
	Medium <sup>1</sup>	0.5	6.0	10.0	0.4
	Low <sup>1</sup>	0.3	6.0	10.0	0.4

$L_{avg}$  = minimum maintained average pavement luminance

$L_{min}$  = minimum pavement luminance

$L_{max}$  = maximum pavement luminance

$L_{Vmax}$  = maximum veiling luminance

1. Pedestrian Classifications: High = over 100 pedestrians/hour, Medium = 1 to 100 pedestrians/hour, Low 10 or fewer pedestrians/hour.

## SPECIFICATIONS AND PROVISIONS

2. Municipality of Chatham-Kent's Road Classification System vs RP-8 Road Classification:

Municipality of Chatham-Kent		RP-8
Arterial	<->	Major
Major Collector	<->	Collector
Residential or Minor Collector	<->	Local
Industrial	<->	Local

3. Luminance on the pavement is based on the quantity and direction of light, observer location, and the pavement reflectance characteristics. The overall average luminance of the road surface as observed from a specific point in cd/m<sup>2</sup> and the observer position per RP-8, latest edition, is 1.45m above the pavement surface and with a line of sight is 1 degree below the horizontal.

All intersections are now required to be evaluated separately, in addition to, the street and roadway lighting photometric, to provide adequate illumination at these higher traffic and activity areas, where safety is a concern. The intersections are to be measured using the horizontal illuminance method.

The illumination guidelines in the chart below have been reproduced from RP-8 to assist the Designer with the intersection analysis. Statistical analysis of each intersection should be provided as part of the lighting design for review in addition to the individual street summaries. The road classifications listed in **Table 6** are as per the road classifications of RP-8.

**Table 6: Illumination for Intersections**

Functional Classification	Average Maintained Illumination at Pavement by Pedestrian Area Classification in Lux/fc			Eavg/Emin
	High	Medium	Low	
Major / Major <sup>2</sup>	34.0/3.4	26.0/2.6	18.0/1.8	3.0
Major / Collector <sup>2</sup>	29.0/2.9	22.0/2.2	15.0/1.5	3.0
Major / Local <sup>2</sup>	26.0/2.6	20.0/2.0	13.0/1.3	3.0
Collector / Collector <sup>2</sup>	24.0/2.4	18.0/1.8	12.0/1.2	4.0
Collector / Local <sup>2</sup>	21.0/2.1	16.0/1.6	10.0/1.0	4.0
Local / Local <sup>2</sup>	18.0/1.8	14.0/1.4	8.0/0.8	6.0

Eavg = minimum maintained average horizontal illuminance at pavement

Emin = minimum horizontal illuminance at pavement

1. Pedestrian Classifications: High = over 100 pedestrians/hour, Medium = 1 to 100 pedestrians/hour, Low 10 or fewer pedestrians/hour
2. Municipality of Chatham-Kent's Road Classification System vs RP-8 Road Classification:

Municipality of Chatham-Kent		RP-8
------------------------------	--	------



## SPECIFICATIONS AND PROVISIONS

---

Arterial	<->	Major
Major Collector	<->	Collector
Residential or Minor Collector	<->	Local
Industrial	<->	Local

### 3.8 Light Intensity Standards

1. The following Principles are to be adopted for the lighting of private and public lands, subject to Site Plan approval, in the Municipality of Chatham-Kent:
  - a) Contribute to personal safety
  - b) Support the supervision of secure areas
  - c) Assist in way finding
  - d) Conserve energy
  - e) Preserve the experience of the night sky
  - f) Respect the privacy of residential space
  - g) Respect animal habitat
  - h) Heighten the enjoyment of public space and night time activity
  - i) Apply the above listed guiding principles consistently
2. To insure the provisions of adequate and safe, full cut off lighting levels, bonding for the provision of on-site lighting may be required as a condition of site plan approvals.
3. Lighting plans and photometric data including IES format files (as required) must be prepared, and all lighting be installed and maintained by the Owner, in accordance with lighting plans, to their best ability (for all development sites of 2300 m<sup>2</sup> building lot , or greater) which will be approved and enforced by the Municipality of Chatham-Kent.
4. The Sign By-law 78-2001, (as amended), shall be reviewed with regards to externally lit billboards and electronic changing copy signs and their impact on the night sky and traffic safety.
5. The lighting requirements for public right-of-ways and other publicly owned lands will be reported by Chatham Administration to Council on every application.
6. All Site Plan applications, in their review and approval, shall be consistent with the Guiding Principals in Recommendation and implement as required the techniques including in “Techniques to Implement Lighting Guiding Principles”; **Table 7**: Illumination Requirements and **Table 5**: Guidelines for Structure Lighting.

### 3.9 Techniques to Implement Lighting Guiding Principles

1. Contribute to personal safety

## SPECIFICATIONS AND PROVISIONS

---

- a) Provide minimum illumination in accordance with Table 1: Illumination Requirement
  - b) Locate lamps so as to avoid glare
  - c) Provide additional shielding of lamp fixtures to avoid glare
  - d) Provide uniform lighting without sudden light to dark transitions
  - e) Provide overlap of light distribution
  - f) Provide illumination to articulate steps
  - g) Coordinate spacing and height of lamps with landscaping to ensure lighting coverage is not interrupted
2. Support the supervision of secure areas
    - a) Provide illumination in accordance with **Table 7**: Illumination Requirements
    - b) Provide good colour rendering for identification purposes using acceptable street lighting standards outline in Section 6
    - c) Provide sufficient lighting coverage including building recesses or inside corners
3. Assist in finding way
    - a) Provide illumination to improve legibility of notes, landmarks and circulation areas
    - b) Align lamps in consistent, recognizable and unambiguous patterns
    - c) Provide a uniform and modest brightness along paths of travel
4. Conserve energy
    - a) Maintain light levels within recommended range set out in Table 1: Illumination Requirements
    - b) Employ alternatives to best conserve energy
    - c) Dim down lighting to minimum levels after normal operating hours (where r required/ requested)
5. Preserve the experience of the night sky
    - a) Light pollution is considered undesirable and many feel that it reduces the enjoyment of night sky.
    - b) Provide full cut-off lighting (zero percent of peak intensity radiating above 90 degrees and 10 percent of peak intensity above 80 degrees) or employ low cut-off where full cut-off lighting alternatives are not feasible, as approved by the Municipality of Chatham-Kent. As LED fixtures can't be fully evaluated in terms of full, semi-cutoff or non-cutoff terms, and as the movement towards anti-light pollution increases, a new system has been implemented jointly by IESNA and IDA to evaluate luminaires. The MLO (Model Lighting Ordinance) uses the BUG (note 8) rating of the fixture shall be in compliance with TM-15, issued by IESNA and IDA.

## SPECIFICATIONS AND PROVISIONS

---

- c) For all area lighting, luminaries should be equipped with devices for re-directing light such as shields, visors or hoods.
  - d) Beacon lights are strongly discouraged unless the application requires such lighting, and as approved by the Municipality of Chatham-Kent.
6. Respect the privacy of residential space
- a) Locate lamps to direct light away from neighbouring properties
  - b) Provide supplementary shielding of lamps to direct light away from neighbouring properties
  - c) Provide lamp fixture mounting heights that avoid glare to the vantage point of neighbouring residential units
  - d) Provide recessed light fixtures that avoid glare to the vantage point of neighbouring residential units
7. Respect animal habitat
- a) Direct illumination away from abutting Municipal Parks and naturalized areas on abutting private lands
8. Heighten the enjoyment of public space and night time activity
- a) Provide minimum illumination to encourage night time use
  - b) Minimize glare using shielding of fully recessed light fixtures, as required
  - c) Reveal the salient features of a site using a combination of diffused and spot lighting
9. Apply the above listed standards consistently
- a) Provide photometric plans and lamp specifications for use by Municipal staff in the review of site plan applications and for inclusion in site plan development approval agreements

Illuminance determines the amount of light incident on a surface, measured in lux or footcandles. Illuminance levels provide an effective method of measuring the performance of a lighting design therefore Designers shall use the Illuminance method for their analysis.

Illuminance uniformity is measured by the ratios Maximum to Minimum and Average to Minimum. These ratios provide a measure of the consistency of lighting across a site and provide assurance that the illuminance is within a range that the human eye can properly discern all objects in its field of view.

The following chart indicates the required illuminance levels for various types of facility's or usages.

**Table 7: Illuminance Requirements**

## SPECIFICATIONS AND PROVISIONS

Uses	Horizontal Illumination (footcandles)		Vertical Illumination (footcandles)	
	Min.	Max.	Min.	Max.
Uncovered Parking Area	0.5	4.0	0.5	4.0
Covered Parking Area	2.0	10.0	5	25.0
Covered Outdoor Area	0.5	10.0	5	25.0
Walkway	0.5	2.0	0.5	5.0
Principle Building Entrance	3.5	8.0	3.5	8.0
Loading and Garage Storage Area	1.0	2.0	5.0	25.0
Covered Gas Pumping Area	5.0	25.0	5.0	50.0
Outdoor Active Recreation Facility Values vary per recreational activity and shall be verified with IESNA standards (latest edition)	1.0	150.0	1.0	150.0
Auto Dealership Display	1.0	8.0	1.0	8.0
Outdoor Storage Yard	1.0	2.5	1.0	2.5
All Non-residential uses at normal non-business hours (11:00pm to 5:00am) and when employees other than security personnel are not present	0.5	2.0	0.5	2.0
All other uses	0.5	2.0	0.5	10.0

None of the minimums noted above apply to adjacent property lines.

Illumination levels at all property lines shall be as close to 0.0 foot-candles as possible to respect private properties surrounding the area.

Fully shielded is assumed in all references.

Luminaires will be full cut-off unless otherwise provided with IESNA BUG rating.

### 3.10 Submission Requirements for Outdoor Lighting

For each site plan requiring submission of an Outdoor Lighting Plan, the Designer must submit the following information as a minimum for review by the Municipality of Chatham-Kent:

- Location of all buildings, structures, property lines, parking, loading and amenity areas.
- Location of all lights, poles and transformer units.
- Mounting height, quantity, orientation and arrangement of all lighting.

## SPECIFICATIONS AND PROVISIONS

---

- Type of light source.
- Manufacturer's catalogue information and detail of the fixture.
- Illumination levels for all proposed fixtures.
- Calculation summary indicating the minimum value, maximum value, maximum-to-minimum ratio and average-to-minimum ratio.
- Submission should include the project name, designer and date whether on a cover sheet or on the drawings itself.
- Include all external lighting to the site under evaluation where it may be considered to be a relevant contribution to the new site.
- Extend photometric analysis past site property lines to evaluate any horizontal illumination that would contribute to light trespass onto neighbouring properties.
- All other relevant information

### 3.11 Guidelines for Structure Lighting

1. The illumination of structures that consist of uniformly dark materials or that contain reflective-coated glass is discouraged.
2. The illumination of tall, slender structures or monuments, such as flagpoles, where stray light is difficult or impossible to control, is discouraged.
3. Equip luminaires with devices to eliminate stray light as much as possible. Examples of such devices are four-sided shields, internal louvers, and top visors.
4. Locate structure lighting luminaires in places where the unshielded light source cannot be seen by pedestrians or motorists.
5. Average illuminance levels (vertical, measured at the structure face):
  - a. Bright surroundings and light surfaces: 1.0 to 5.0 foot-candles
  - b. Bright surroundings and medium surfaces: 1.0 to 6.0 foot-candles
  - c. Dark surroundings and light surfaces: 0.5 to 2.0 foot-candles
  - d. Dark surroundings and medium surfaces: 0.5 to 3.0 foot-candles

### 3.12 Definitions

1 Foot-candle = 10 Lux

Full Cut Off Lighting: "A light fixture constructed in such a manner that all light emitted by the fixture, either directly from the lamp or a diffusing element, or indirectly by reflection or refraction from any part of the luminaire, is projected below the horizontal." Horizontal Illuminance = "The measurement of brightness from a light source, usually measured in foot-candles or lumens, which is taken through a light meter's sensor at a horizontal position."

IDA: "International Dark Sky Association"

IESNA: "Illuminating Engineering Society of North America"

## SPECIFICATIONS AND PROVISIONS

---

Light Pollution: “Any adverse effect of artificial light including, but not limited to, glare, light trespass, sky-glow, energy waste, compromised safety and security, and impacts on the nocturnal environment”.

Luminance: “the measure of brightness of a point on a surface that is radiating or reflecting light, measured in candelas per square meter, it is the photometric measure of luminous intensity, per unit area of light travelling in a given direction”.

Vertical Illumination: “The measurement of brightness from a light source, usually measured in foot-candles or lumens, which is taken through a light meter’s sensor at a vertical position.”

### 3.13 Backfill and Compaction

Trench backfill and compaction shall generally be in conformance with the minimum requirements outlined in the Trench Backfill Details included in **Appendix B – “Design Drawings, Figures & Details.”** Based on site specific soil conditions, geotechnical recommendations for alternative degrees of native backfill compaction should be confirmed by a qualified geotechnical engineer. Recycled materials are acceptable provided they meet provincial requirements.

### 3.14 Restoration and Landscaping

Restoration of all boulevard areas disturbed as a result of the construction of site services shall be completed to match the existing conditions, but not less than 100 mm topsoil and seed and mulch for maintained lawn areas.

The Owner must have a landscape plan prepared by a professional landscaping firm and it is to be reviewed and approved by Chatham-Kent. The following guidelines should be considered by the landscape firm in the landscape design for median/ boulevard areas:

1. The plan should be designed with low maintenance features in mind.
2. The plan should strive to provide environmental benefits for the community.
3. The plan should create a more aesthetically pleasing environment.
4. The plan should include additional features such as trees, shrubbery, landscape stone or mulch, decorative rocks, and other pleasing features.
5. The plan should enhance a sense of personal safety and reduce the opportunity of crime by facilitating the unobstructed observation of public spaces and areas (Crime Prevention through Environmental Design).

The general principles of CPTED are outlined below:

**Natural Surveillance:** Criminals do not want to be seen. Barriers like shrubs, clutter, or shadows can impair visibility/view corridors. The correct placement of these barriers prevents loss of natural surveillance/self-policing.

**Territoriality:** Owners tend to protect their space through visible border definition. Fences, pavement treatments, and art murals are some ways of expressing ownership. Identifying intruders and law breakers is easier in well-defined spaces.

## SPECIFICATIONS AND PROVISIONS

---

**Access Control:** Properly located entrances, exits, fencing, and lighting can discourage criminal behaviour. It may be a tasteful, well placed sign, or a parking lot with highly visible pavement markings.

**Target Hardening:** Use motion-activated flood lighting in the “back” of public areas.

**Activity Management:** Encouraging legitimate activity in public spaces discourages crime. Increase the sense of natural surveillance and sense of ownership.

**Behaviour Engineering:** Changes in the placement and arrangement of physical attributes influences behaviour; essentially “Architectural Risk Management.”

### **3.15 Recycled Material**

Only recycled material approved by the Province and Municipality of Chatham-Kent may be used. Chatham-Kent reserves the right to request engineered and environmental reports on the acceptability of the recycled material for specific intended uses at the Owner’s expense.

### **3.16 Other Utilities**

The Engineer will be responsible to co-ordinate the efforts of other public utilities as a result of conflicts with proposed services and/ or upgrading to accommodate the new Development.

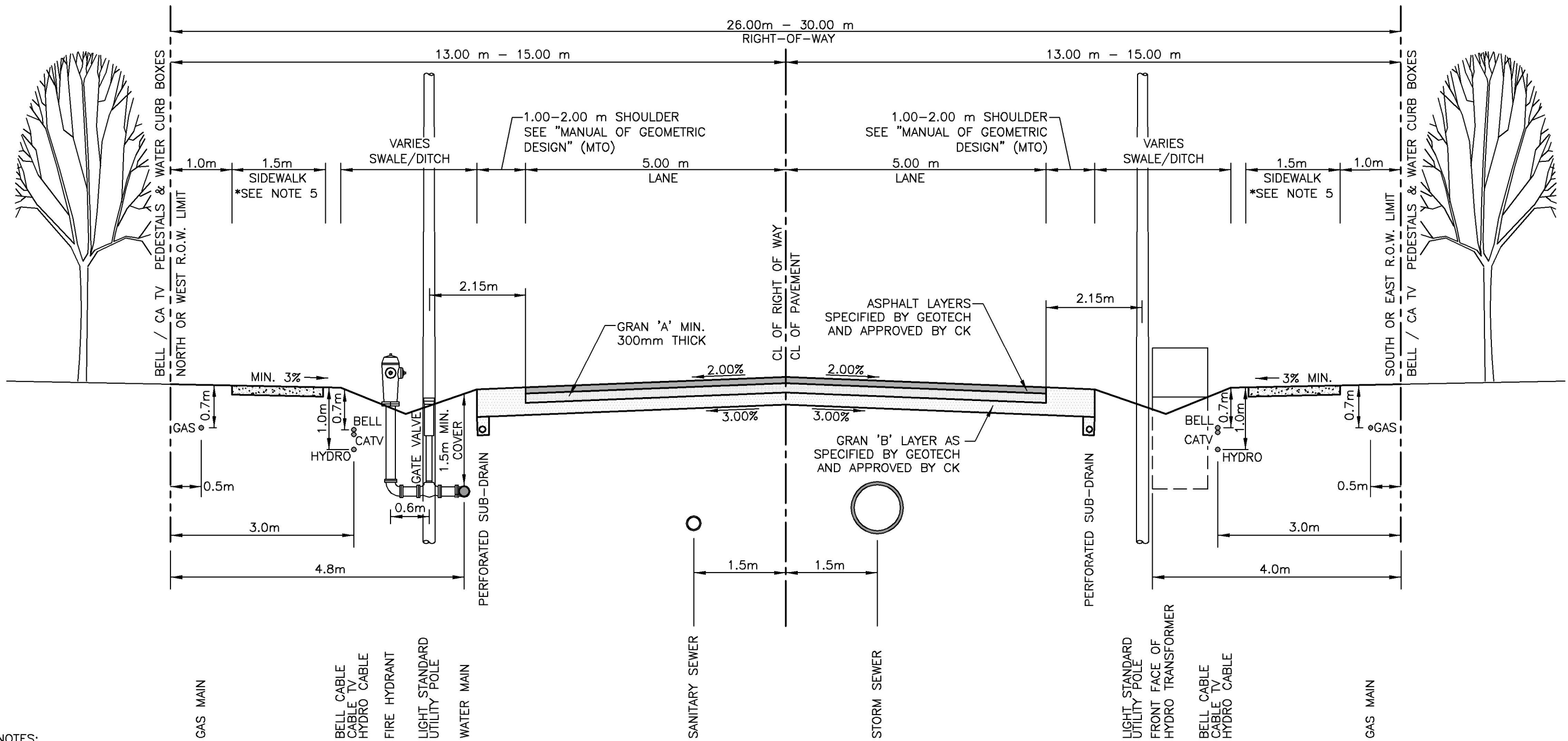

**NOTES:**

1. THE ABOVE CROSS SECTION IS INTENDED TO BE A GUIDELINE FOR LOCATION OF UTILITY CORRIDORS WITHIN NEW SUBDIVISIONS AND ROADWAYS. THE CORRIDOR LOCATIONS SHOULD ALSO BE CONSIDERED WHERE POSSIBLE WHEN NEW UTILITY PLANTS ARE TO BE CONSTRUCTED WITHIN EXISTING ROAD ALLOWANCES.
2. VERTICAL DIMENSIONS TO UTILITY PLANT ARE GUIDELINES ONLY AND SHOULD BE CONFIRMED WITH THE UTILITY COMPANY. DIMENSIONS SHOWN ARE TO TOP OF FINISHED GRADE, AND IT IS THEREFORE ESSENTIAL THAT GRADING BE COMPLETED TO OUTER EDGE OF RIGHT-OF-WAY BEFORE UTILITY INSTALLATION AND BE WITHIN 15cm OF FINAL GRADE.
3. NO TWO (2) ABOVE GROUND UTILITIES ON THE SAME LOT FRONTAGE.
4. HYDRO, BELL AND CABLE TV TO BE INSTALLED IN JOINT TRENCH.
5. SIDEWALK TO BE 1.50m WIDTH ONE SIDE OF R.O.W. ONLY FOR LOCAL STREETS. SIDEWALK TO BE 1.50m WIDTH BOTH SIDES OF R.O.W. FOR COLLECTOR AND ARTERIAL STREETS.

FILENAME: C:\PROJECTS\WORKING DIRECTORY\3333\3333\3333\175615-02-FR-COR-01.DWG PLOTTED BY: JAV, LOGAN  
 PLOT DATE: 2018-02-15 14:55:00 PM PLOT SCALE: 1:1 PLOT STYLE: DULON-STANDARD.CTB



No.	1	March 06, 2018
		Revision Date

Municipality of Chatham-Kent Development Manual

**Figure CS-1**  
 Typical Road Cross Section  
 Rural Arterial Road - 26-30m R.O.W.



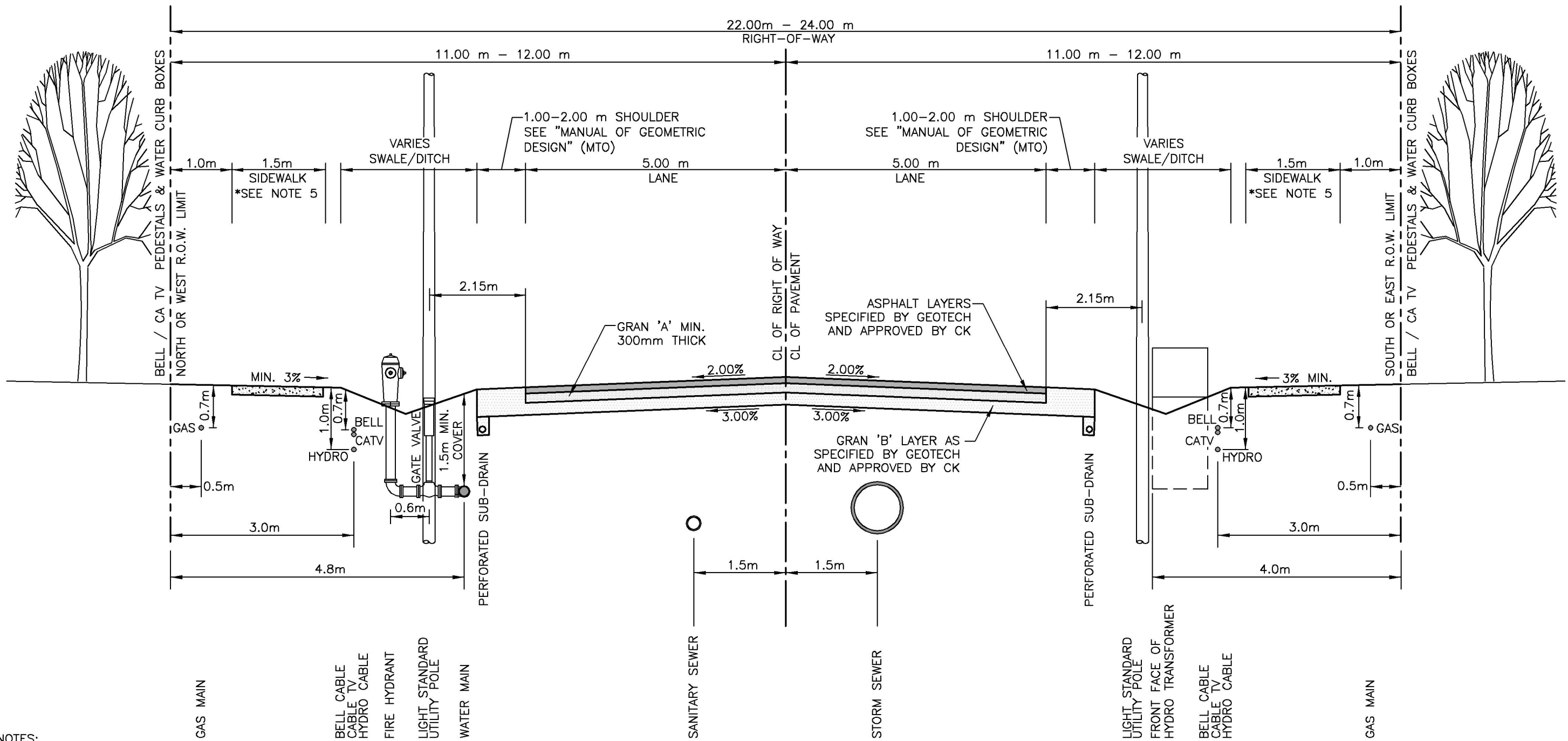

**NOTES:**

1. THE ABOVE CROSS SECTION IS INTENDED TO BE A GUIDELINE FOR LOCATION OF UTILITY CORRIDORS WITHIN NEW SUBDIVISIONS AND ROADWAYS. THE CORRIDOR LOCATIONS SHOULD ALSO BE CONSIDERED WHERE POSSIBLE WHEN NEW UTILITY PLANTS ARE TO BE CONSTRUCTED WITHIN EXISTING ROAD ALLOWANCES.
2. VERTICAL DIMENSIONS TO UTILITY PLANT ARE GUIDELINES ONLY AND SHOULD BE CONFIRMED WITH THE UTILITY COMPANY. DIMENSIONS SHOWN ARE TO TOP OF FINISHED GRADE, AND IT IS THEREFORE ESSENTIAL THAT GRADING BE COMPLETED TO OUTER EDGE OF RIGHT-OF-WAY BEFORE UTILITY INSTALLATION AND BE WITHIN 15cm OF FINAL GRADE.
3. NO TWO (2) ABOVE GROUND UTILITIES ON THE SAME LOT FRONTAGE.
4. HYDRO, BELL AND CABLE TV TO BE INSTALLED IN JOINT TRENCH.
5. SIDEWALK TO BE 1.50m WIDTH ONE SIDE OF R.O.W. ONLY FOR LOCAL STREETS. SIDEWALK TO BE 1.50m WIDTH BOTH SIDES OF R.O.W. FOR COLLECTOR AND ARTERIAL STREETS.

FILENAME: C:\PROJECTS\WORKING DIRECTORY\3333\3333\3333\175615-02-FR-CONV.DWG PLOTTED BY: JAV, LOGAN  
 PLOT DATE: 2018-02-15 14:52:24 PM PLOT SCALE: 1:1 PLOT STYLE: DULON-STANDARD.CTB



No.	1	March 06, 2018
		Revision Date

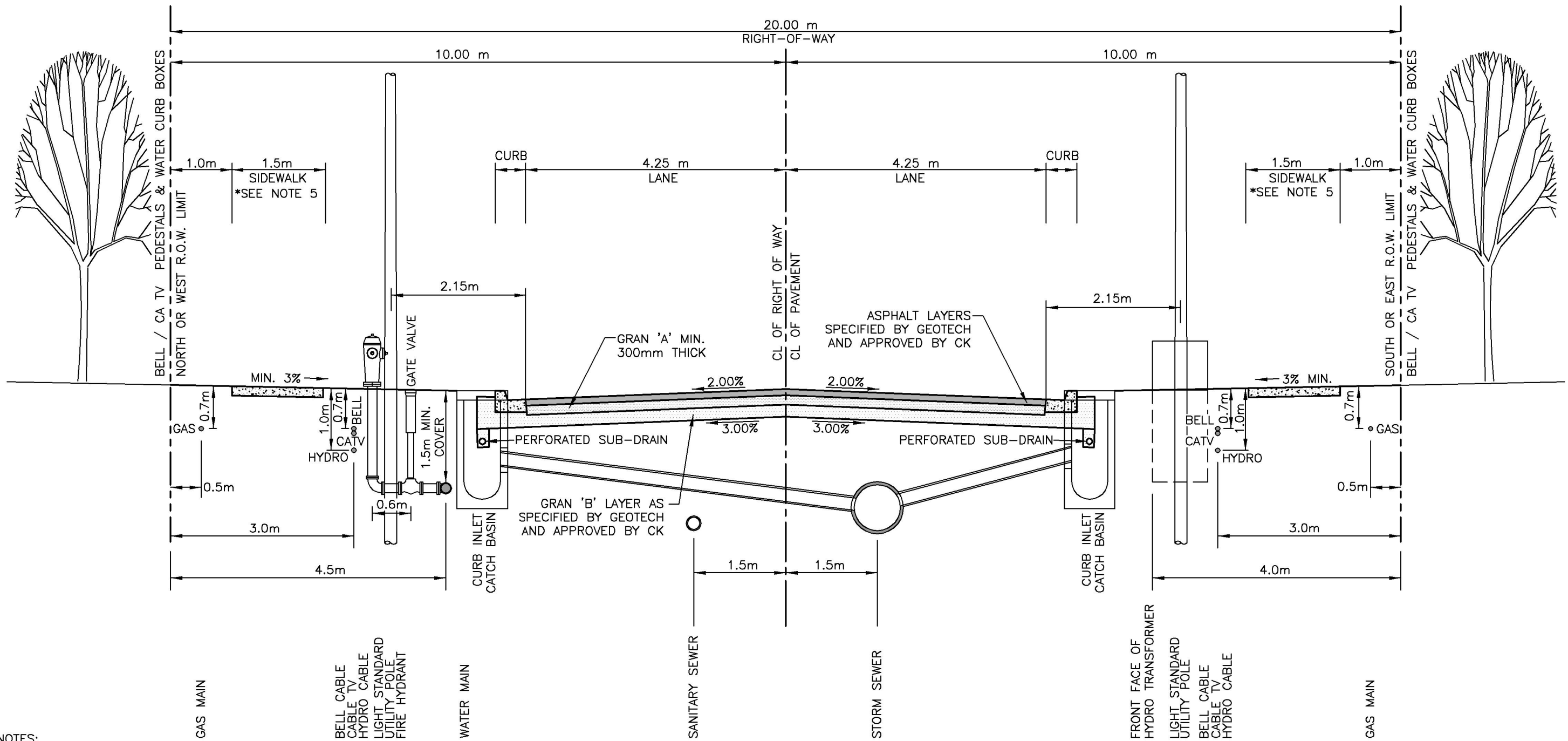

**NOTES:**

1. THE ABOVE CROSS SECTION IS INTENDED TO BE A GUIDELINE FOR LOCATION OF UTILITY CORRIDORS WITHIN NEW SUBDIVISIONS AND ROADWAYS. THE CORRIDOR LOCATIONS SHOULD ALSO BE CONSIDERED WHERE POSSIBLE WHEN NEW UTILITY PLANTS ARE TO BE CONSTRUCTED WITHIN EXISTING ROAD ALLOWANCES.
2. VERTICAL DIMENSIONS TO UTILITY PLANT ARE GUIDELINES ONLY AND SHOULD BE CONFIRMED WITH THE UTILITY COMPANY. DIMENSIONS SHOWN ARE TO TOP OF FINISHED GRADE, AND IT IS THEREFORE ESSENTIAL THAT GRADING BE COMPLETED TO OUTER EDGE OF RIGHT-OF-WAY BEFORE UTILITY INSTALLATION AND BE WITHIN 15cm OF FINAL GRADE.
3. NO TWO (2) ABOVE GROUND UTILITIES ON THE SAME LOT FRONTAGE.
4. HYDRO, BELL AND CABLE TV TO BE INSTALLED IN JOINT TRENCH.
5. SIDEWALK TO BE 1.50m WIDTH ONE SIDE OF R.O.W. ONLY FOR LOCAL STREETS. SIDEWALK TO BE 1.50m WIDTH BOTH SIDES OF R.O.W. FOR COLLECTOR AND ARTERIAL STREETS.

FILENAME: C:\PROJECTS\WORKING DIRECTORY\333\A\050159\175615-02-FG-COR-01.DWG PLOTTED BY: JAV, LOGAN  
 PLOT DATE: 2018-02-15 14:52:24 PM PLOT SCALE: 1:1 PLOT STYLE: DULON-STANDARD.CTB



No.	1	March 06, 2018
		Revision Date

Municipality of Chatham-Kent Development Manual

**Figure CS-3**  
 Typical Road Cross Section  
 Urban Typical Road - 20m R.O.W.

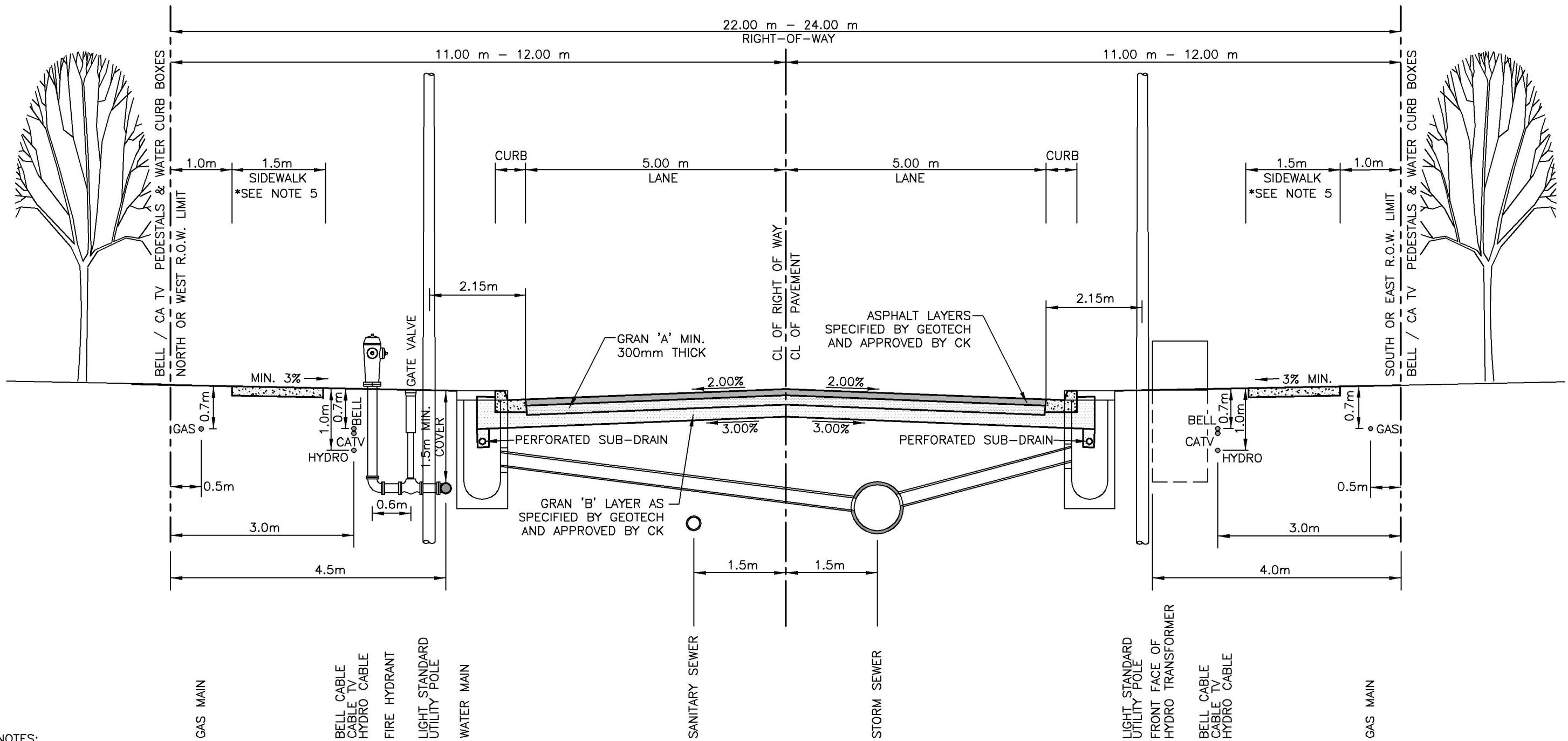

**NOTES:**

1. THE ABOVE CROSS SECTION IS INTENDED TO BE A GUIDELINE FOR LOCATION OF UTILITY CORRIDORS WITHIN NEW SUBDIVISIONS AND ROADWAYS. THE CORRIDOR LOCATIONS SHOULD ALSO BE CONSIDERED WHERE POSSIBLE WHEN NEW UTILITY PLANTS ARE TO BE CONSTRUCTED WITHIN EXISTING ROAD ALLOWANCES.
2. VERTICAL DIMENSIONS TO UTILITY PLANT ARE GUIDELINES ONLY AND SHOULD BE CONFIRMED WITH THE UTILITY COMPANY. DIMENSIONS SHOWN ARE TO TOP OF FINISHED GRADE, AND IT IS THEREFORE ESSENTIAL THAT GRADING BE COMPLETED TO OUTER EDGE OF RIGHT-OF-WAY BEFORE UTILITY INSTALLATION AND BE WITHIN 15cm OF FINAL GRADE.
3. NO TWO (2) ABOVE GROUND UTILITIES ON THE SAME LOT FRONTAGE.
4. HYDRO, BELL AND CABLE TV TO BE INSTALLED IN JOINT TRENCH.
5. SIDEWALK TO BE 1.50m WIDTH ONE SIDE OF R.O.W. ONLY FOR LOCAL STREETS. SIDEWALK TO BE 1.50m WIDTH BOTH SIDES OF R.O.W. FOR COLLECTOR AND ARTERIAL STREETS.

FILENAME: C:\PROJECTS\WORKING DIRECTORY\333\A\0501590\175615-02-FG-COR-01.DWG PLOTTED BY: JAV, LOGAN  
 PLOT DATE: 2018-02-15 14:53:33 PM PLOT SCALE: 1:1 PLOT STYLE: DULON-STANDARD.CTB



No.	1	March 06, 2018
		Revision Date

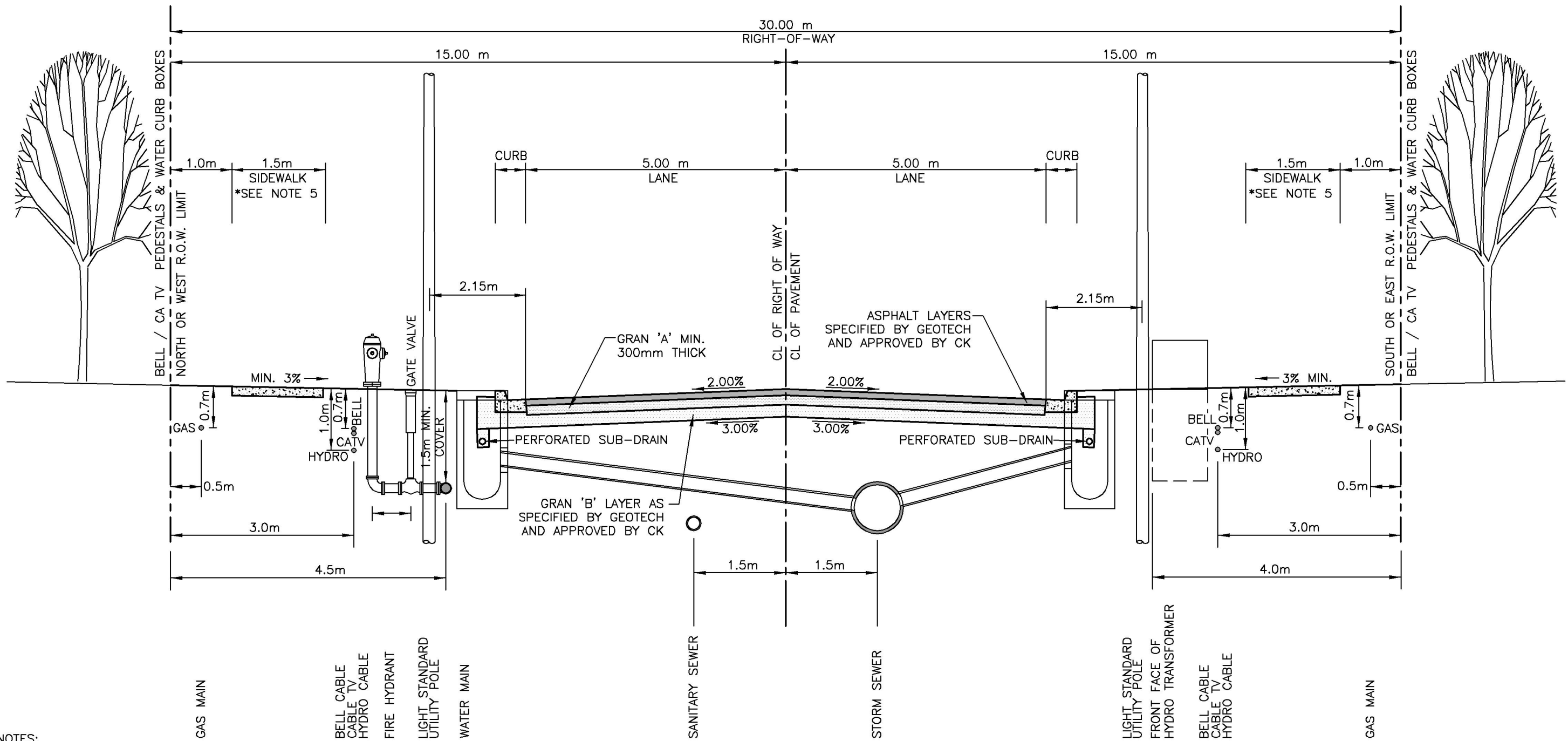

**NOTES:**

1. THE ABOVE CROSS SECTION IS INTENDED TO BE A GUIDELINE FOR LOCATION OF UTILITY CORRIDORS WITHIN NEW SUBDIVISIONS AND ROADWAYS. THE CORRIDOR LOCATIONS SHOULD ALSO BE CONSIDERED WHERE POSSIBLE WHEN NEW UTILITY PLANTS ARE TO BE CONSTRUCTED WITHIN EXISTING ROAD ALLOWANCES.
2. VERTICAL DIMENSIONS TO UTILITY PLANT ARE GUIDELINES ONLY AND SHOULD BE CONFIRMED WITH THE UTILITY COMPANY. DIMENSIONS SHOWN ARE TO TOP OF FINISHED GRADE, AND IT IS THEREFORE ESSENTIAL THAT GRADING BE COMPLETED TO OUTER EDGE OF RIGHT-OF-WAY BEFORE UTILITY INSTALLATION AND BE WITHIN 15cm OF FINAL GRADE.
3. NO TWO (2) ABOVE GROUND UTILITIES ON THE SAME LOT FRONTAGE.
4. HYDRO, BELL AND CABLE TV TO BE INSTALLED IN JOINT TRENCH.
5. SIDEWALK TO BE 1.50m WIDTH ONE SIDE OF R.O.W. ONLY FOR LOCAL STREETS. SIDEWALK TO BE 1.50m WIDTH BOTH SIDES OF R.O.W. FOR COLLECTOR AND ARTERIAL STREETS.

FILENAME: C:\PROJECTS\WORKING DIRECTORY\3333\3333\175615-02-FG-COR-01.DWG PLOTTED BY: JAV, LOGAN  
 PLOT DATE: 2018-02-15 14:54 PM PLOT SCALE: 1:1 PLOT STYLE: DULON-STANDARD.CTB



No.	1	March 06, 2018
		Revision Date

Municipality of Chatham-Kent Development Manual

**Figure CS-5**  
 Typical Road Cross Section  
 Urban Arterial Road - 30m R.O.W.

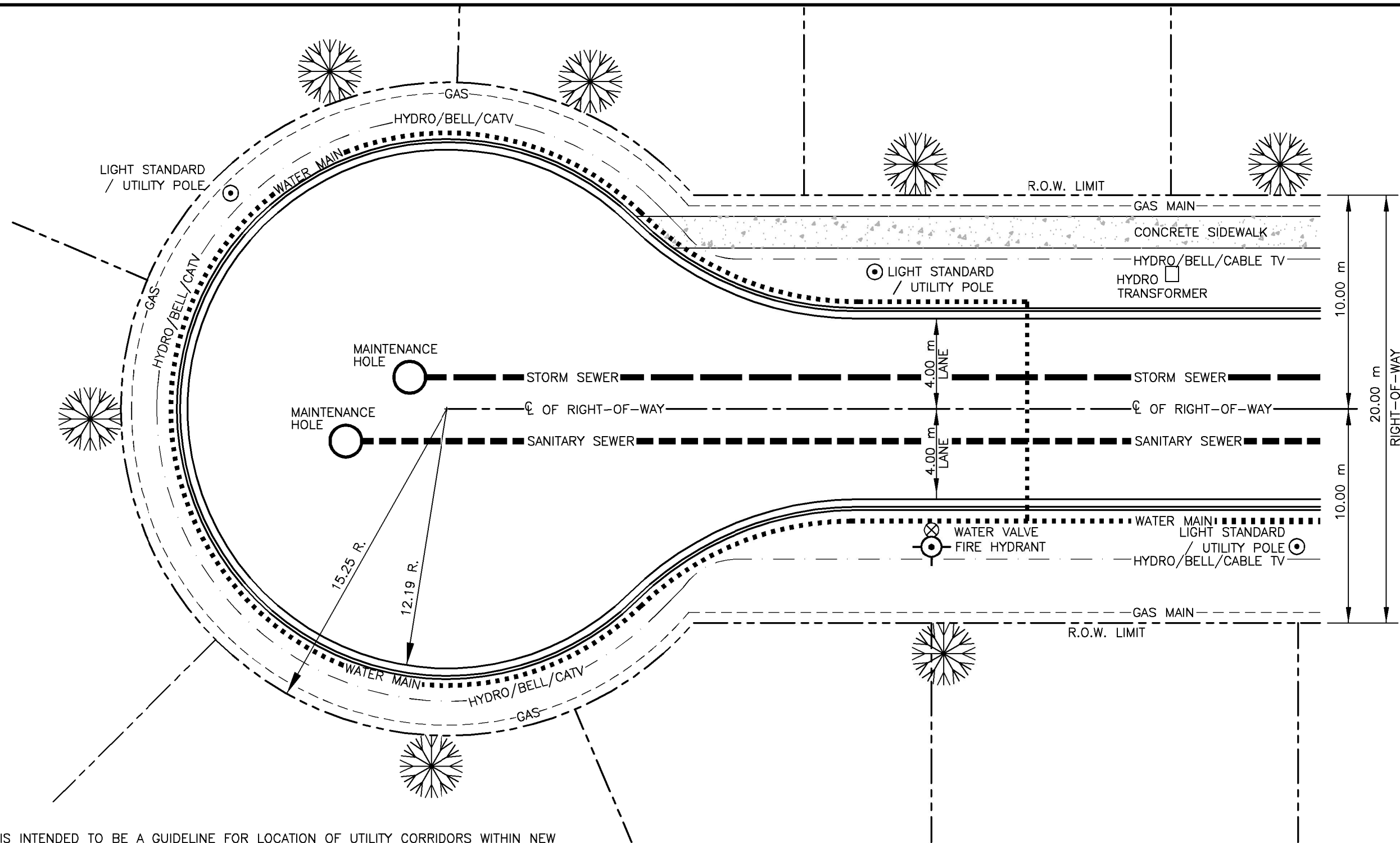

**NOTES:**

1. THE ABOVE IS INTENDED TO BE A GUIDELINE FOR LOCATION OF UTILITY CORRIDORS WITHIN NEW SUBDIVISIONS AND ROADWAYS. THE CORRIDOR LOCATIONS SHOULD ALSO BE CONSIDERED WHERE POSSIBLE WHEN NEW UTILITY PLANTS ARE TO BE CONSTRUCTED WITHIN EXISTING ROAD ALLOWANCES.
2. REFER TO STANDARD UTILITY CROSS SECTION DRAWINGS FOR VERTICAL AND HORIZONTAL DIMENSIONING TO EACH UTILITY PLANT.
3. NO TWO (2) ABOVE GROUND UTILITIES ON THE SAME LOT FRONTAGE.
4. HYDRO, BELL AND CABLE TV TO BE INSTALLED IN JOINT TRENCH.
5. SIDEWALK TO BE 1.50m WIDTH ONE SIDE OF R.O.W. ONLY FOR LOCAL STREETS. SIDEWALK TO BE 1.50m WIDTH BOTH SIDES OF R.O.W. FOR COLLECTOR AND ARTERIAL STREETS.
6. CONSIDERATION SHALL BE MADE FOR LOCATIONS OF DRIVEWAY ENTRANCES WHEN LOCATING ABOVE GROUND UTILITIES ON LOT FRONTAGES.

FILENAME: C:\PROJECTS\WORKING DIRECTORY\ACTIVE\337815\060175615-02-PC-CORRIDOR PLOTTED BY: STIRLING, TODD  
 PLOT DATE: 2018-04-19 @ 10:52:08 AM PLOT SCALE: 1:1 PLOT STYLE: D:\LOW-STANDARD.CTB



No.	1	March 06, 2018
		Revision Date

Municipality of Chatham-Kent Development Manual

**Figure CS-6**  
 Typical Road Cross Section  
 20.0m R.O.W. -CUL-DE-SACS

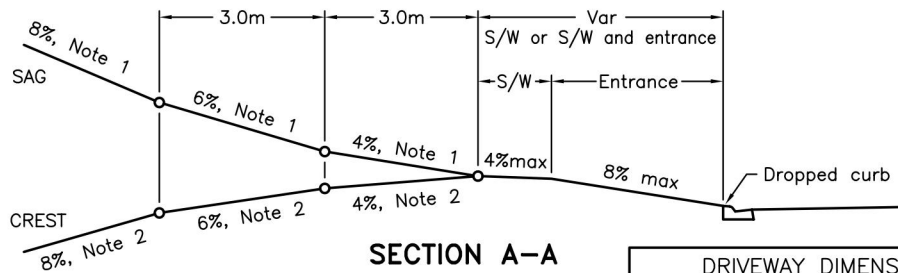
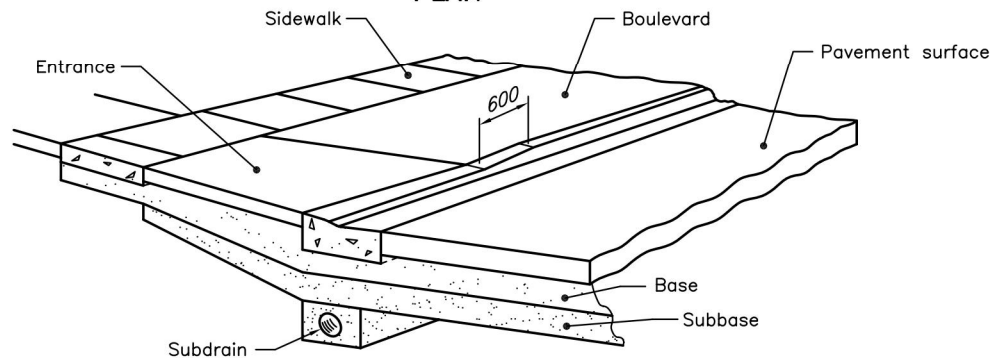
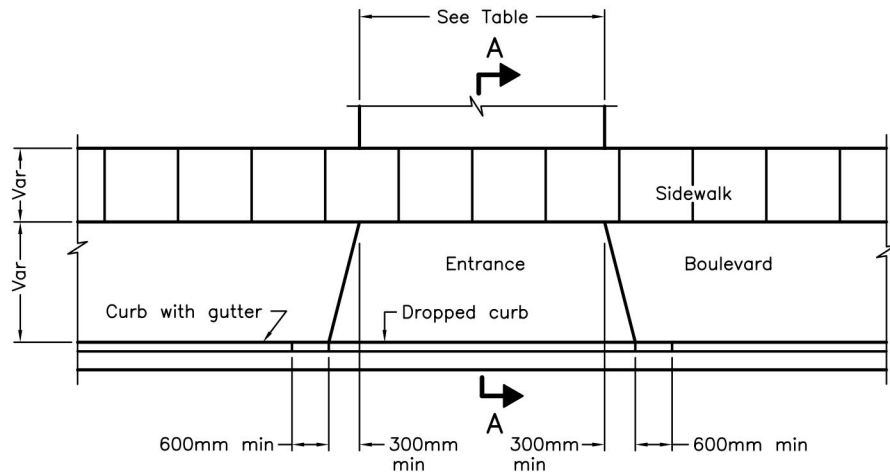

**NOTES:**

- 1 Maximum upgrade shall be 10%.
- 2 Maximum downgrade shall be 8%.

A All dimensions are in millimetres unless otherwise shown.

DRIVEWAY DIMENSIONS				
LAND USE	WIDTH m			
	Single		Double	
	min	max	min	max
Residential	3.0	4.3	6.0	7.3

ONTARIO PROVINCIAL STANDARD DRAWING		Nov 2009	Rev	1
<b>URBAN RESIDENTIAL ENTRANCE</b>		OPSD 351.010		



**NOTES**

- 1. SEE DETAIL D-3 FOR STANDARD CROSS SECTIONS



Municipality of Chatham-Kent Development Manual

**Figure D-1**

Urban Residential Entrance

OPSD 351.010

1	March 06, 2018
No.	Revision Date

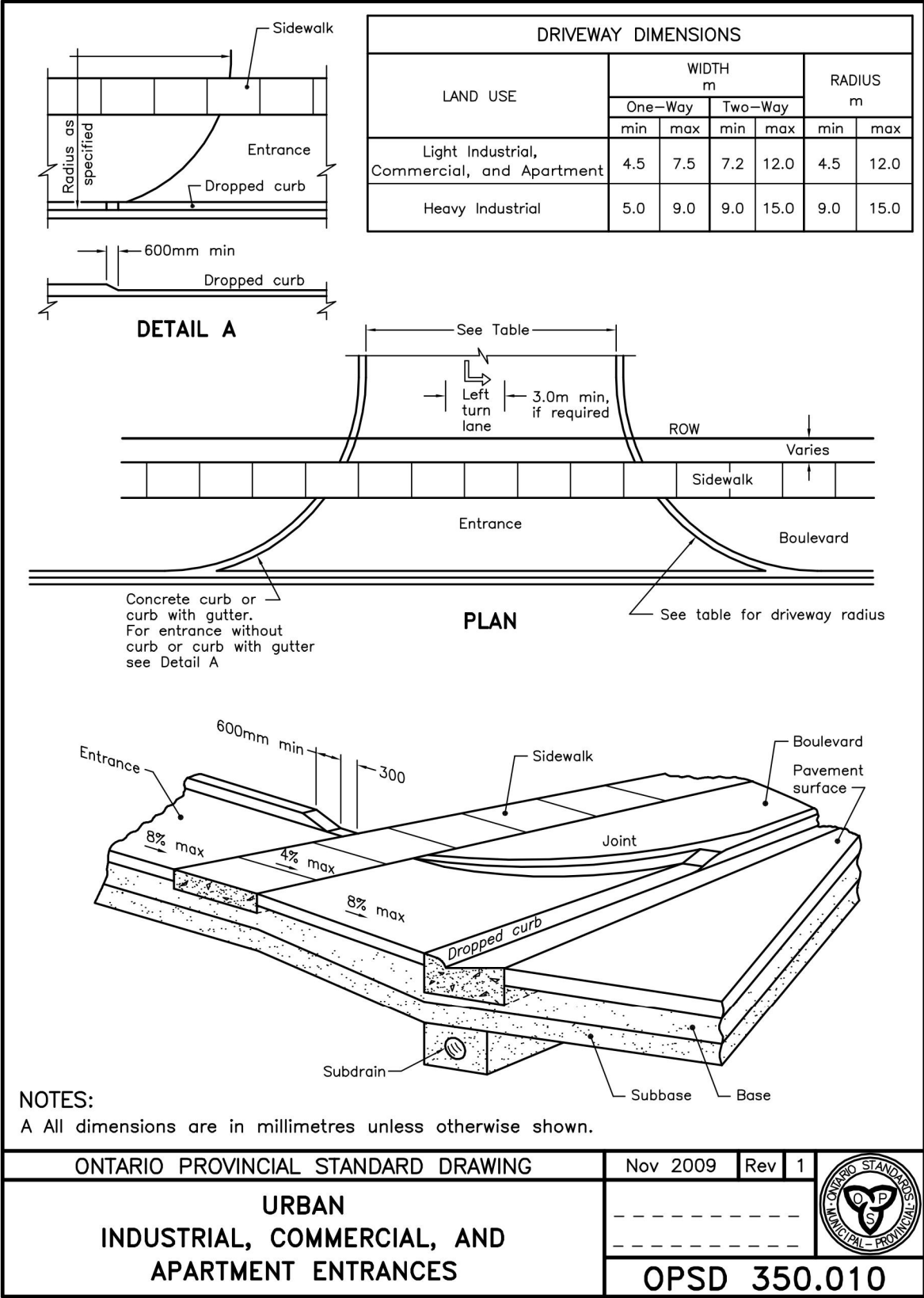

ONTARIO PROVINCIAL STANDARD DRAWING		Nov 2009	Rev 1	
<b>URBAN INDUSTRIAL, COMMERCIAL, AND APARTMENT ENTRANCES</b>		-----		
		<b>OPSD 350.010</b>		

**NOTES**  
1. SEE DETAIL D-3 FOR STANDARD CROSS SECTIONS

FILENAME: C:\PROJECTS\WORKING DIRECTORY\ACTIVE\STMS\0501560\175415-02-PC-COM.DWG PLOTTED BY: STIRLING, TODD  
 PLOT DATE: 2018-04-02 @ 3:48:43 PM PLOT SCALE: 1:1 PLOT STYLE: DULON-STANDARD.CTB

	Municipality of Chatham-Kent Development Manual		<b>Figure D-2</b> Urban Industrial, Commercial, & Apartment Entrance - OPSD 350.010
	1	March 06, 2018	
	No.	Revision Date	

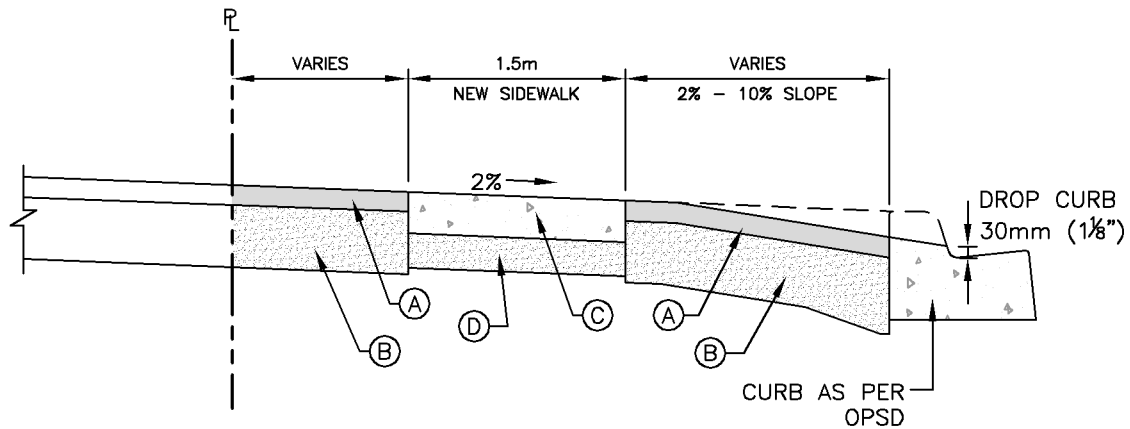

SECTION

RESIDENTIAL DRIVEWAY			
	ASPHALT DRIVEWAY	CONCRETE DRIVEWAY	BRICK PAVERS DRIVEWAY
A	50mm (2") HL3 SURFACE 50mm (2") HL4 BASE	150mm (6") 30 MPa CONCRETE	BRICK PAVERS ON 50mm (2") UNCOMPACTED SAND OR LIMESTONE SCREENINGS
B	150mm (6") COMPACTED GRANULAR 'A'	150mm (6") COMPACTED THICKNESS G.B.C.'A'	200mm (8") GRANULAR 'A' COMPACTED TO 98% SPD
C	150mm (6") 32 MPa CONCRETE	150mm (6") 32 MPa CONCRETE	150mm (6") 32 MPa CONCRETE
D	150mm (6") COMPACTED GRANULAR 'A'	150mm (6") COMPACTED GRANULAR 'A'	150mm (6") COMPACTED GRANULAR 'A'

INDUSTRIAL, COMMERCIAL & APPARTMENT DRIVEWAY			
	ASPHALT DRIVEWAY	CONCRETE DRIVEWAY	BRICK PAVERS DRIVEWAY
A	50mm (2") HL3 SURFACE 50mm (2") HL4 BASE	200mm (8") 30 MPa CONCRETE	N/A
B	300mm (12") COMPACTED GRANULAR 'A'	200mm (8") COMPACTED THICKNESS G.B.C.'A'	N/A
C	200mm (8") 32 MPa CONCRETE	200mm (8") 32 MPa CONCRETE	N/A
D	200mm (8") COMPACTED GRANULAR 'A'	200mm (8") COMPACTED GRANULAR 'A'	N/A

FILENAME: C:\PROJECTS\WORKING DIRECTORY\ACTIVE\TMS\DR01560\175415-02-PC-COM.DWG PLOTTED BY: STIRLING, TODD  
 PLOT DATE: 2018-04-02 @ 3:48:45 PM PLOT SCALE: 1:1 PLOT STYLE: DULON-STANDARD.CTB



1	March 06, 2018
No.	Revision Date

Municipality of Chatham-Kent Development Manual

**Figure D-3**  
 Urban Residential, Industrial, Commercial,  
 & Apartment Entrances - Sections



FILENAME: C:\PROJECTS\WORKING DIRECTORY\OPSD\310.050\175616-02-FIG-CONCRETE PLOTTED BY: STIRLING, 1000  
 PLOT DATE: 2018-04-02 @ 3:46:47 PM PLOT SCALE: 1:1 PLOT STYLE: DILLON-STANDARD.CTB

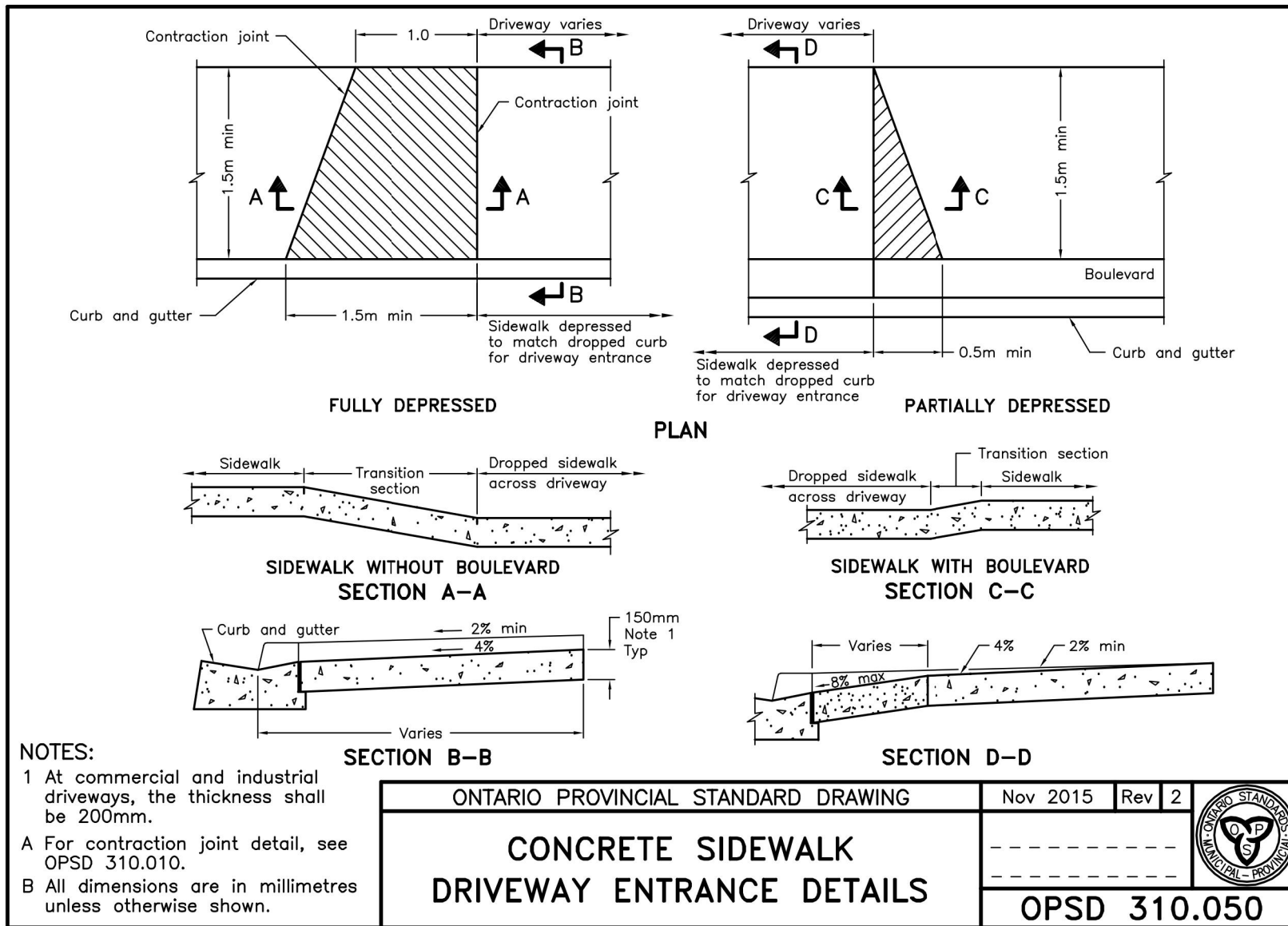

1	March 06, 2018
No.	Revision Date

Municipality of Chatham-Kent Development Manual

**Figure D-4**  
 Residential Driveway Concrete With Sidewalk  
 OPSD 310.050





**POLE SPECIFICATIONS:**

MANUFACTURER: STREESSCRETE  
 CATALOGUE NO.: KBH25-G-E10 C/W  
 140-25/30 & BA

SECTION: OCTAGONAL  
 COLOR: MIDNIGHT LACE  
 FINISH: ETCHED  
 POLE TOP: 5 3/8" FL/FL  
 POLE BUTT: 9 1/2" ø  
 POLE LENGTH: 25' OR TO BE DETERMINED BY DESIGNER  
 APPROX WEIGHT: 1,625 lbs.  
 MIN. RACEWAY: 1 1/8" ø

**COATINGS REQUIRED:**

-2 COATS (JB) ACRYLIC  
 FULL LENGTH

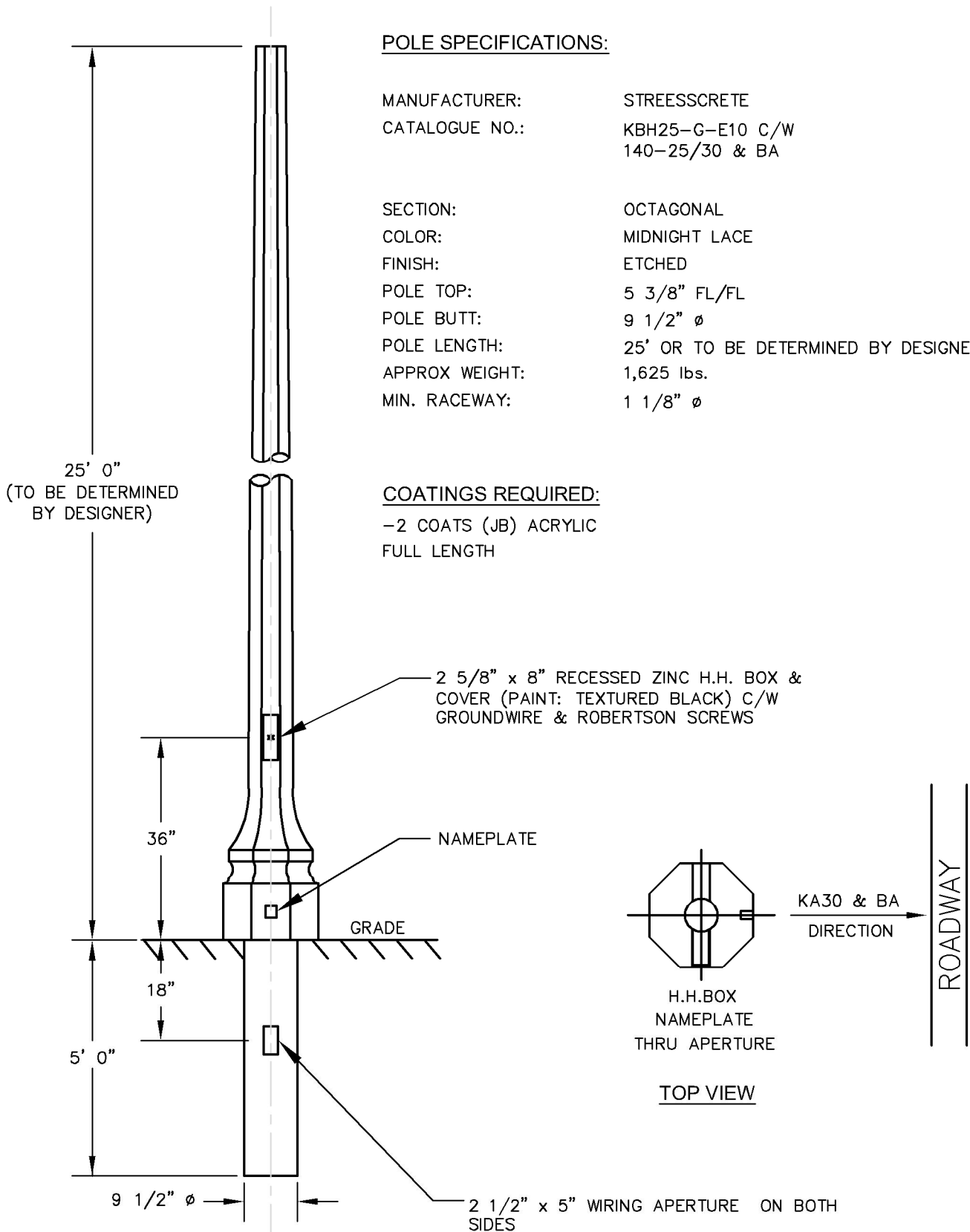

FILENAME: C:\PROJECTS\WORKING DIRECTORY\ACTIVE\3\TMS\DESIGN\175415-02-PC-COM.DWG PLOTTED BY: STIRLING, TODD  
 PLOT DATE: 2018-04-02 @ 3:46:26 PM PLOT SCALE: 1:1 PLOT STYLE: DILLON-STANDARD.CTB

 <p><b>Chatham-Kent</b> Cultivating Growth, Shore to Shore</p>	
	1 March 06, 2018
No.	Revision Date

Municipality of Chatham-Kent Development Manual

**Figure E-3**  
 DECORATIVE POLE DETAIL





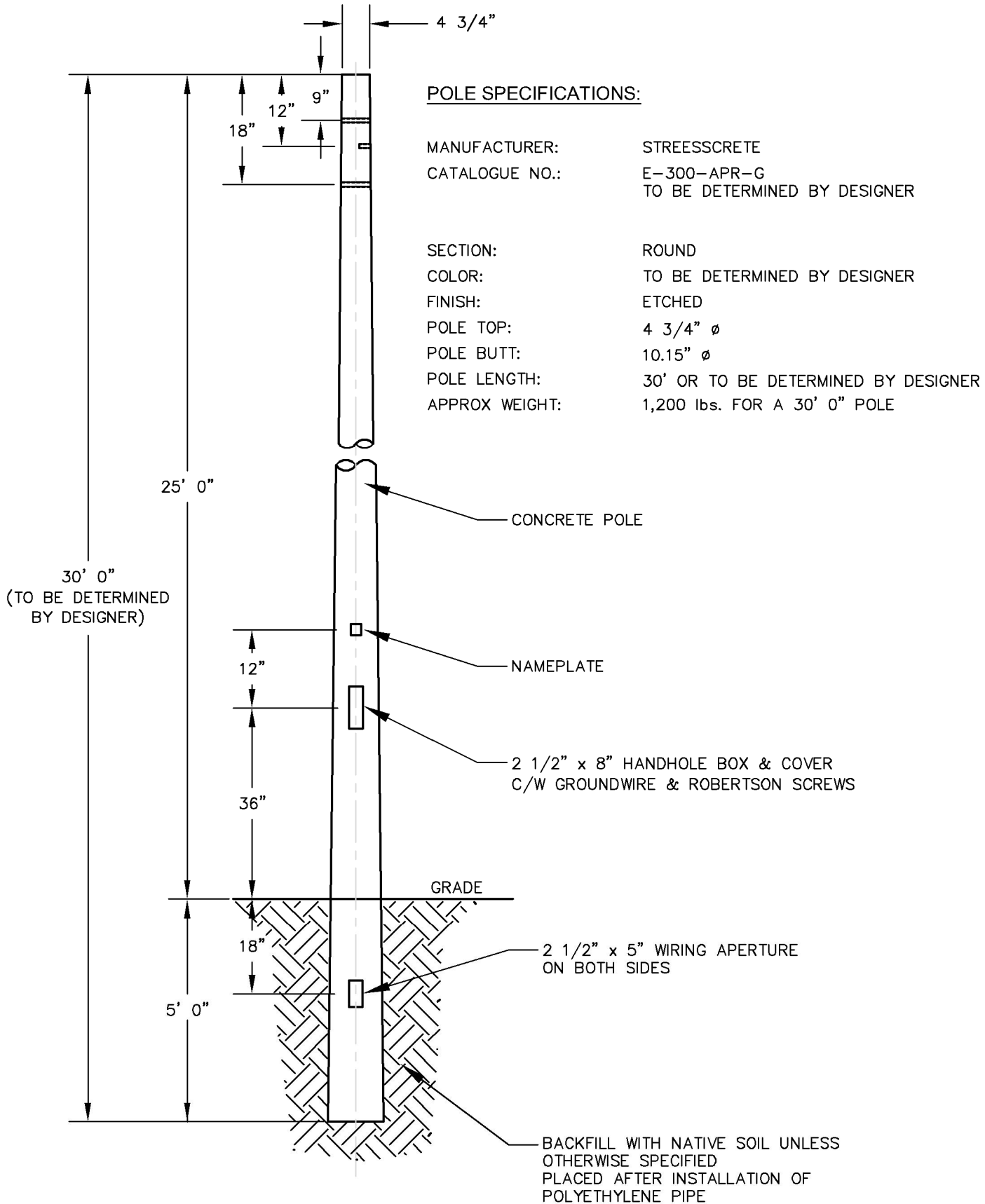

FILENAME: C:\PROJECTS\WORKING DIRECTORY\ACTIVE\3\MS\DESIGN\175415-02-PC-COM.DWG PLOTTED BY: STIRLING, TODD  
 PLOT DATE: 2018-04-02 @ 3:50:01 PM PLOT SCALE: 1:1 PLOT STYLE: DILLON-STANDARD.CTB

 <p><b>Chatham-Kent</b> Cultivating Growth, Shore to Shore</p>	
	1 March 06, 2018
No.	Revision Date

Municipality of Chatham-Kent Development Manual	
<b>Figure E-6</b> STANDARD POLE DETAIL	





2-150mm DIA. INLETS.  
HOLE LOCATION TO  
SUIT REAR YARD DRAIN.

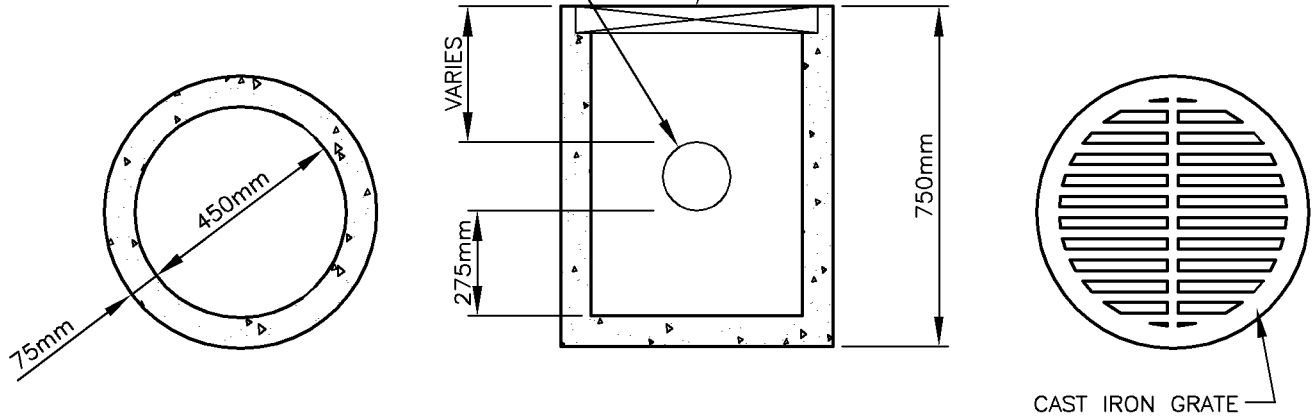

**NOTE:**

1. CONCRETE TO BE 30 MPa, AIR ENTRAINED 6% ± 1 ½%.
2. ALTERNATE REAR YARD CATCH BASINS MAY BE ACCEPTABLE. CHECK WITH CHIEF BUILDING OFFICIAL.

REAR YARD CATCH BASIN  
(CONCRETE)

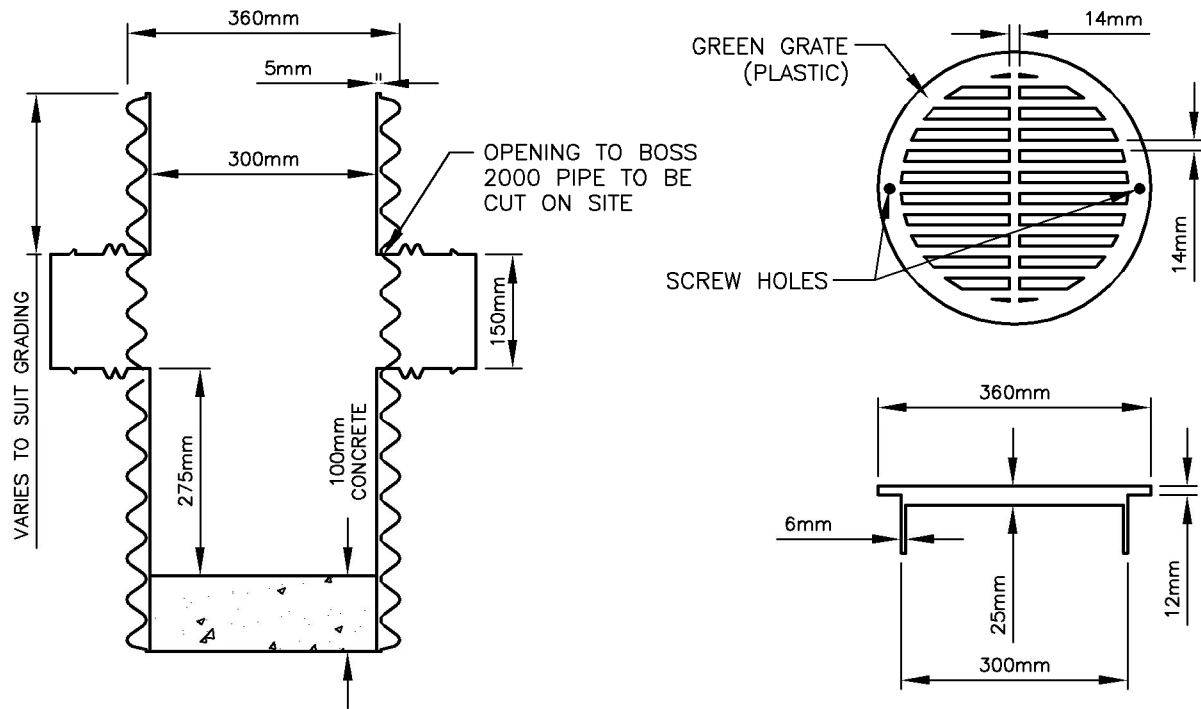

REAR YARD CATCH BASIN  
(PLASTIC)

FILENAME: C:\PROJECTS\WORKING DIRECTORY\ACTIVE\3\TMS\05601560\175415-02-PC-COM.DWG PLOTTED BY: STIRLING, TODD  
PLOT DATE: 2018-04-02 @ 3:46:51 PM PLOT SCALE: 1:1 PLOT STYLE: DILLON-STANDARD.CTB

1	March 06, 2018
No.	Revision Date

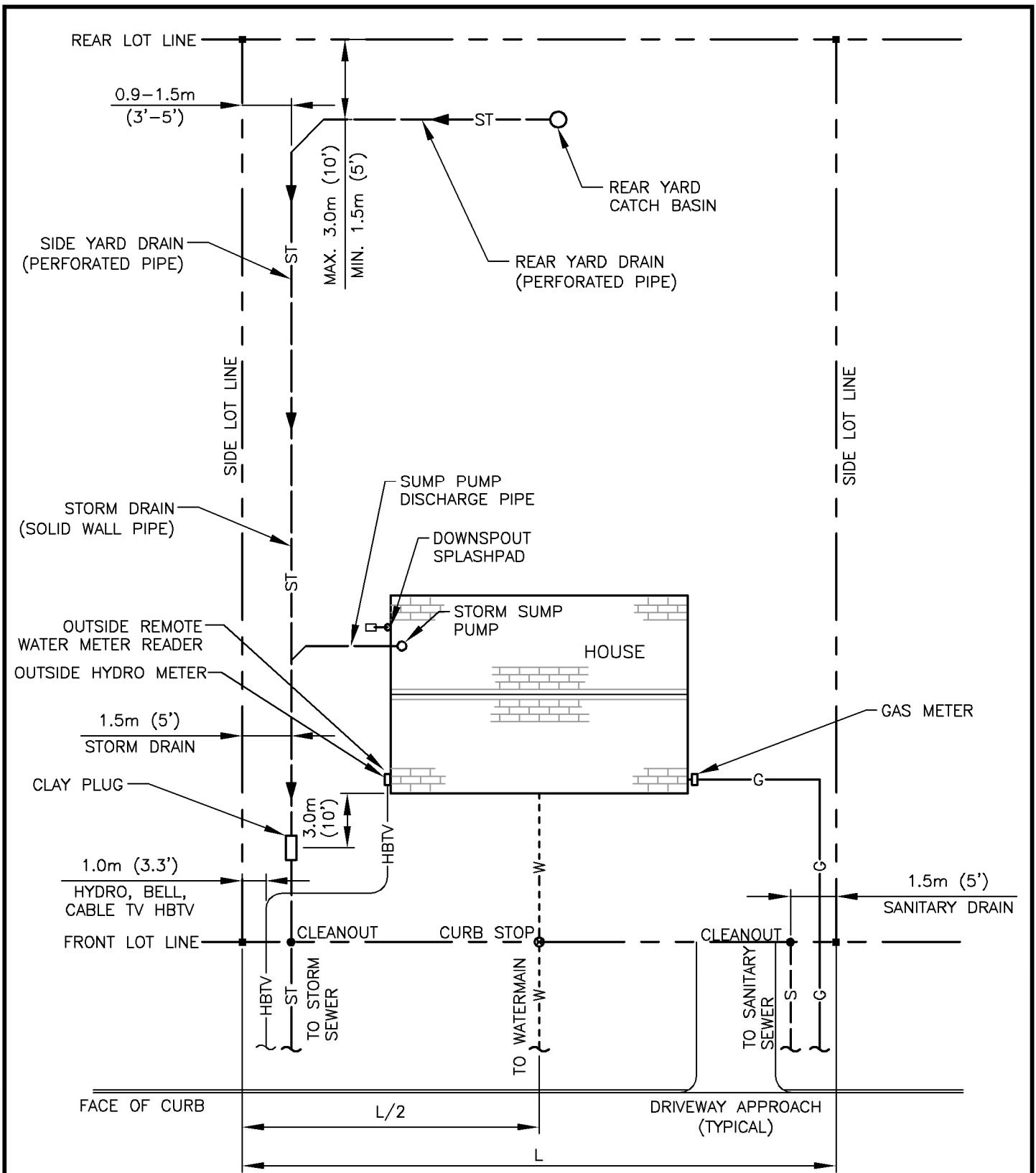

**NOTES:**

1. OFFSETS SHOWN ARE TYPICAL, THEY MAY VARY BASED ON SERVICING DRAWINGS.
2. SEE O.B.C. FOR CLEANOUT SPACING.
3. REAR YARD CATCH BASIN LOCATION TO BE APPROVED BY TOWN.
4. AVOID SANITARY CLEANOUT IN DRIVEWAYS.

FILENAME: C:\PROJECTS\WORKING DIRECTORY\ACTIVE\3\TMS\0501560\175415-02-PC-COMPLING PLOTTED BY: STIRLING, TODD  
 PLOT DATE: 2018-04-02 @ 3:46:53 PM PLOT SCALE: 1:1 PLOT STYLE: DILLON-STANDARD.DWT

		Municipality of Chatham-Kent Development Manual
	<b>Figure L-3</b> LOT SERVICE LOCATIONS	
	1 March 06, 2018	
	No. Revision Date	





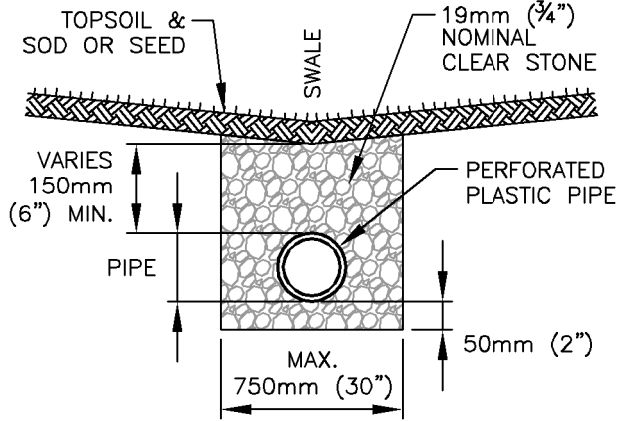

NOTE:  
SETBACK 1.5m (5')  
FROM REAR PROPERTY LINE.

**REAR YARD DRAIN**

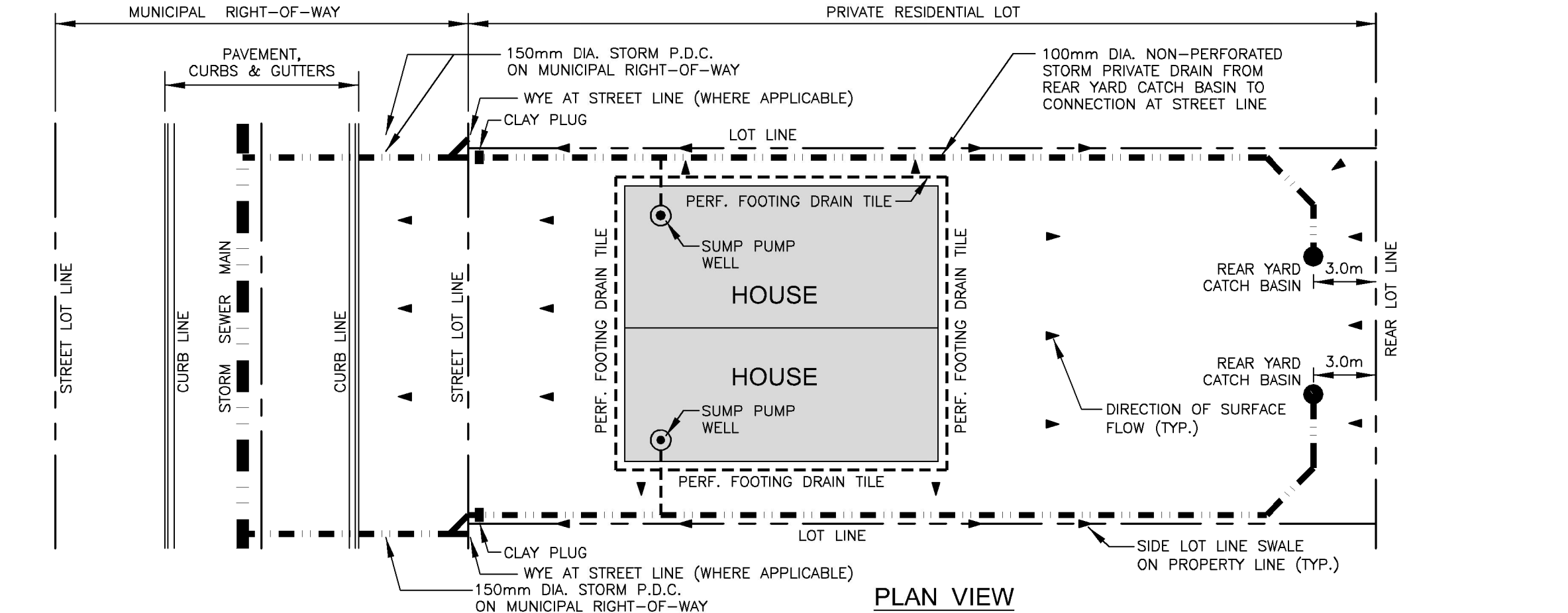

**PLAN VIEW**

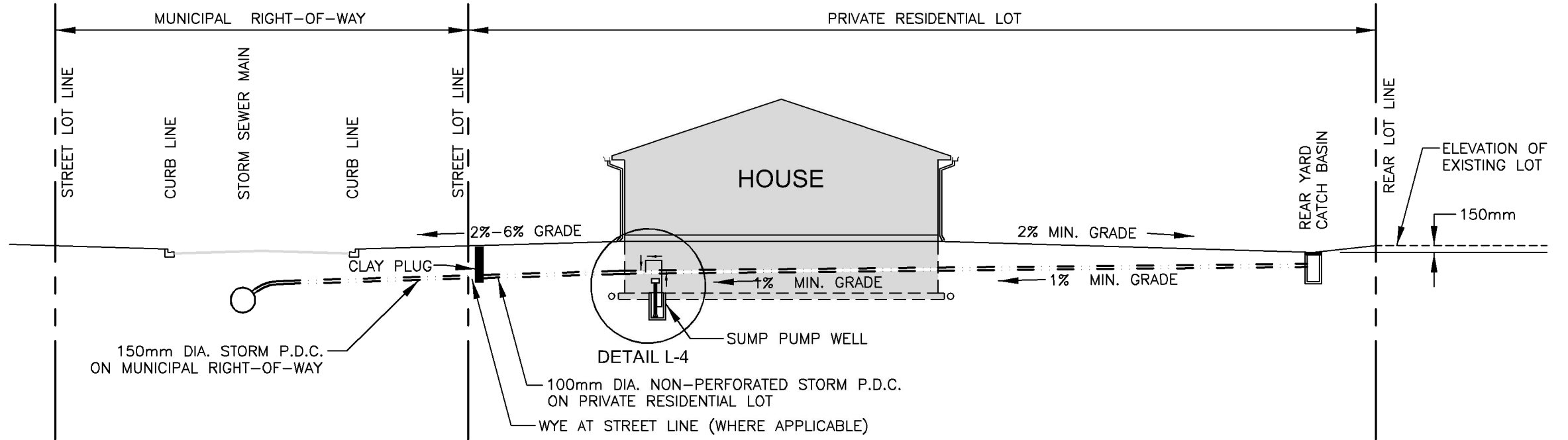

**PROFILE VIEW**

FILENAME: C:\PROJECTS\WORKING DIRECTORY\ACTIVE\337815\060175615-02-PC-COULING PLOTTED BY: STIRLING, TODD  
PLOT DATE: 2018-04-19 @ 10:52:15 AM PLOT SCALE: 1:1 PLOT STYLE: DIALOG-STANDARD.CTB



No.	1	March 06, 2018
		Revision Date

Municipality of Chatham-Kent Development Manual

**Figure L-6**  
SUGGESTED METHOD OF INSTALLATION OF  
A SEMI-DETACHED STORM DRAINAGE SYSTEM

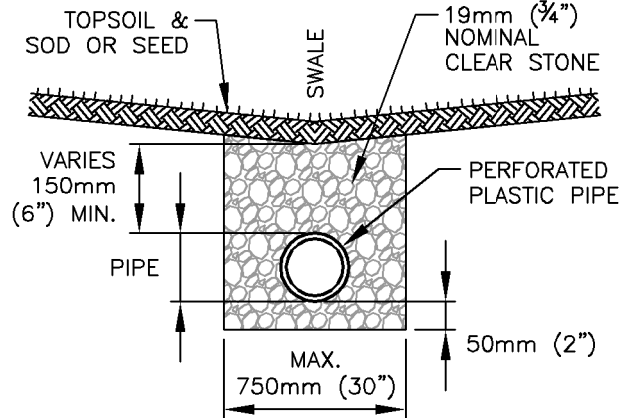

NOTE:  
SETBACK 1.5m (5')  
FROM REAR PROPERTY LINE.

### REAR YARD DRAIN

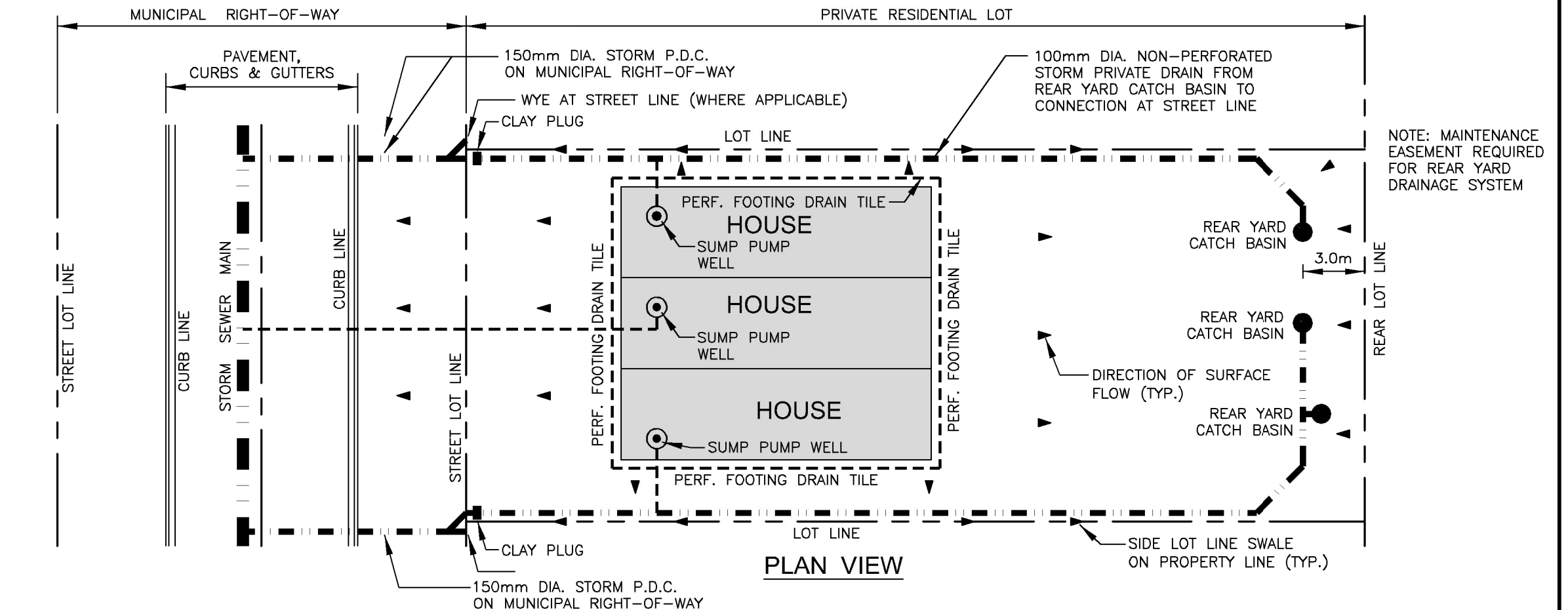

NOTE: MAINTENANCE  
EASEMENT REQUIRED  
FOR REAR YARD  
DRAINAGE SYSTEM

### PLAN VIEW

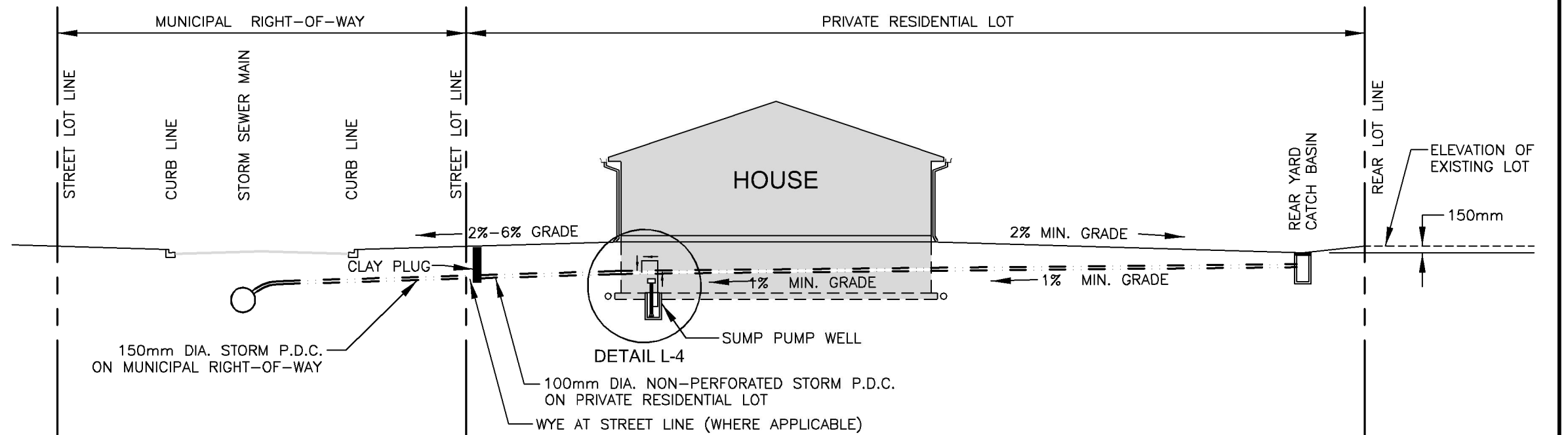

### PROFILE VIEW

FILENAME: C:\PROJECTS\WORKING DIRECTORY\ACTIVE\337815\06011960\175615-02-PC-COULING PLOTTED BY: STIRLING, TODD  
PLOT DATE: 2018-04-19 @ 10:52:18 AM PLOT SCALE: 1:1 PLOT STYLE: DIALOG-STANDARD.CRT

No.	1	March 06, 2018
		Revision Date

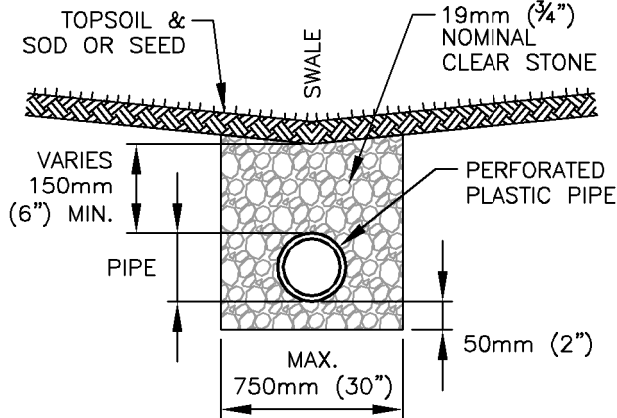

NOTE:  
SETBACK 1.5m (5')  
FROM REAR PROPERTY LINE.

**REAR YARD DRAIN**

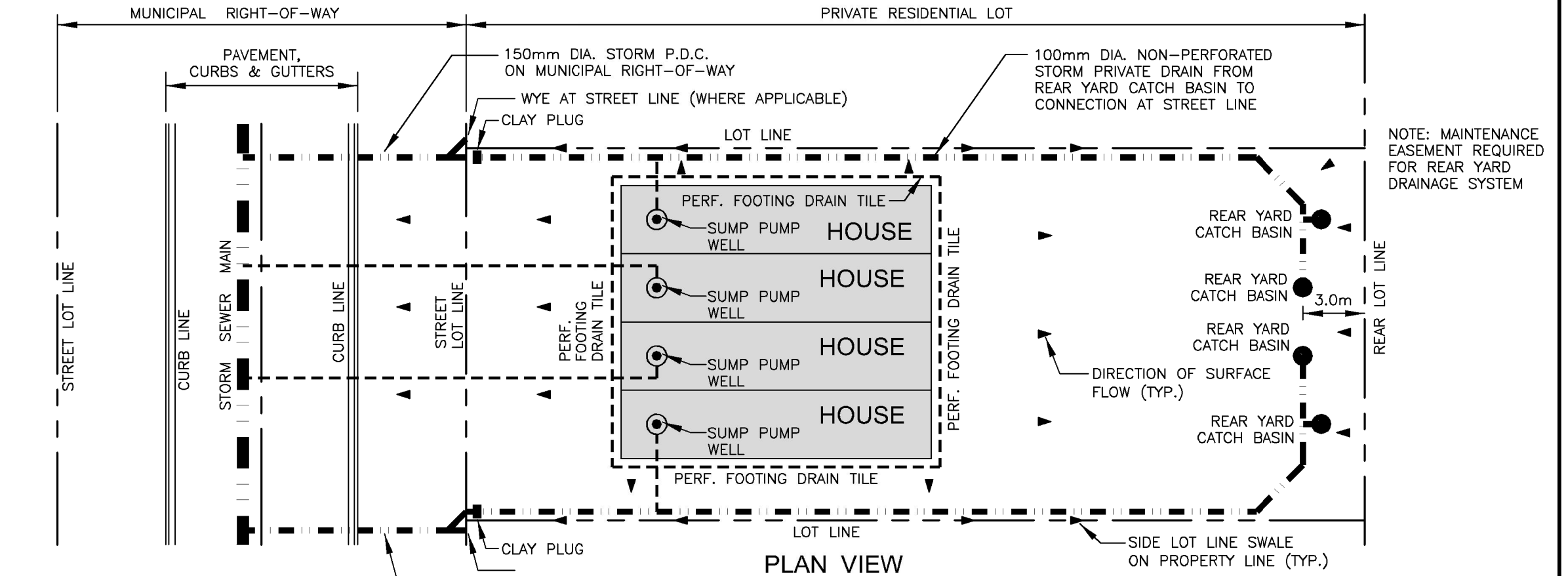

**PLAN VIEW**

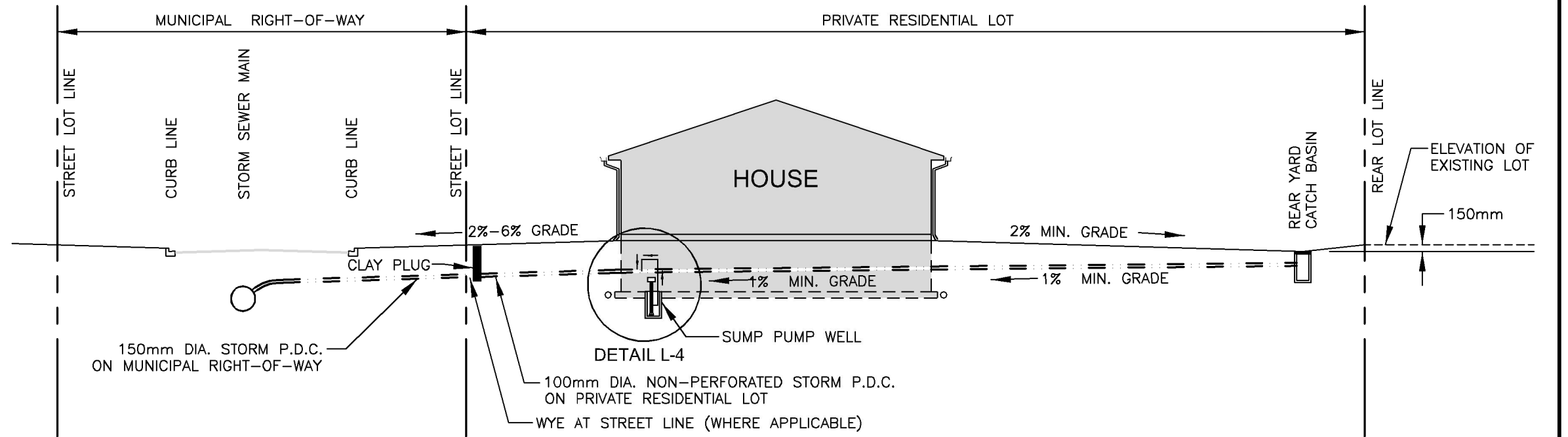

**PROFILE VIEW**

FILENAME: C:\PROJECTS\WORKING DIRECTORY\ACTIVE\337815\060175615-02-PC-COULING PLOTTED BY: STIRLING, TODD  
PLOT DATE: 2018-04-19 10:52:20 AM PLOT SCALE: 1:1 PLOT STYLE: DILLON-STANDARD.CBT



No.	1	March 06, 2018
		Revision Date

Municipality of Chatham-Kent Development Manual

**Figure L-8**  
SUGGESTED METHOD OF INSTALLATION OF A 4  
UNIT TOWN HOUSE STORM DRAINAGE SYSTEM

**NOTES:**

- 1) INSTALLATION OF CLEAN-OUT AND CONNECTING TO THE EXISTING SANITARY SEWER CONNECTION AT STREET LOT LINE SHALL BE CARRIED OUT BY A DRAINAGE/SEWER LAYER CONTRACTOR LICENSED BY THE MUNICIPALITY OF CHATHAM-KENT. MUNICIPALITY OF CHATHAM-KENT BUILDING ENFORCEMENT & LICENSING SERVICES TO BE CONTACTED TO ARRANGE FOR PERMITS AND INSPECTION WHEN MAKING CONNECTION AT STREET LINE.
- 2) ANY CHANGES TO PLUMBING WITHIN A BUILDING WILL REQUIRE ADDITIONAL/SEPARATE PERMIT.
- 3) ALL PLUMBING/DRAINAGE PIPING AND FITTINGS SHALL BE SUPPLIED AND INSTALLED TO CONFORM TO CSA/CAN AND THE ONTARIO BUILDING CODE AND LATEST AMENDMENTS.
- 4) DECOMMISSIONING OF SEPTIC TANKS:
  - SEWAGE TO BE REMOVED BY A SANITARY DISPOSAL CONTRACTOR LICENSED BY THE ONTARIO MINISTRY OF ENVIRONMENT
  - TOP COVER OF SEPTIC TANK MUST BE REMOVED AND CRUSHED INTO THE SEPTIC TANK
  - SEPTIC TANK TO BE FILLED WITH APPROVED, COMPACTED, GRANULAR OR NATIVE SOIL MATERIAL
  - MUNICIPALITY OF CHATHAM-KENT BUILDING AND ENFORCEMENT SERVICES TO BE CONTACTED FOR INSPECTION OF THE DECOMMISSIONED TANK PRIOR TO BACKFILLING WITH SOIL

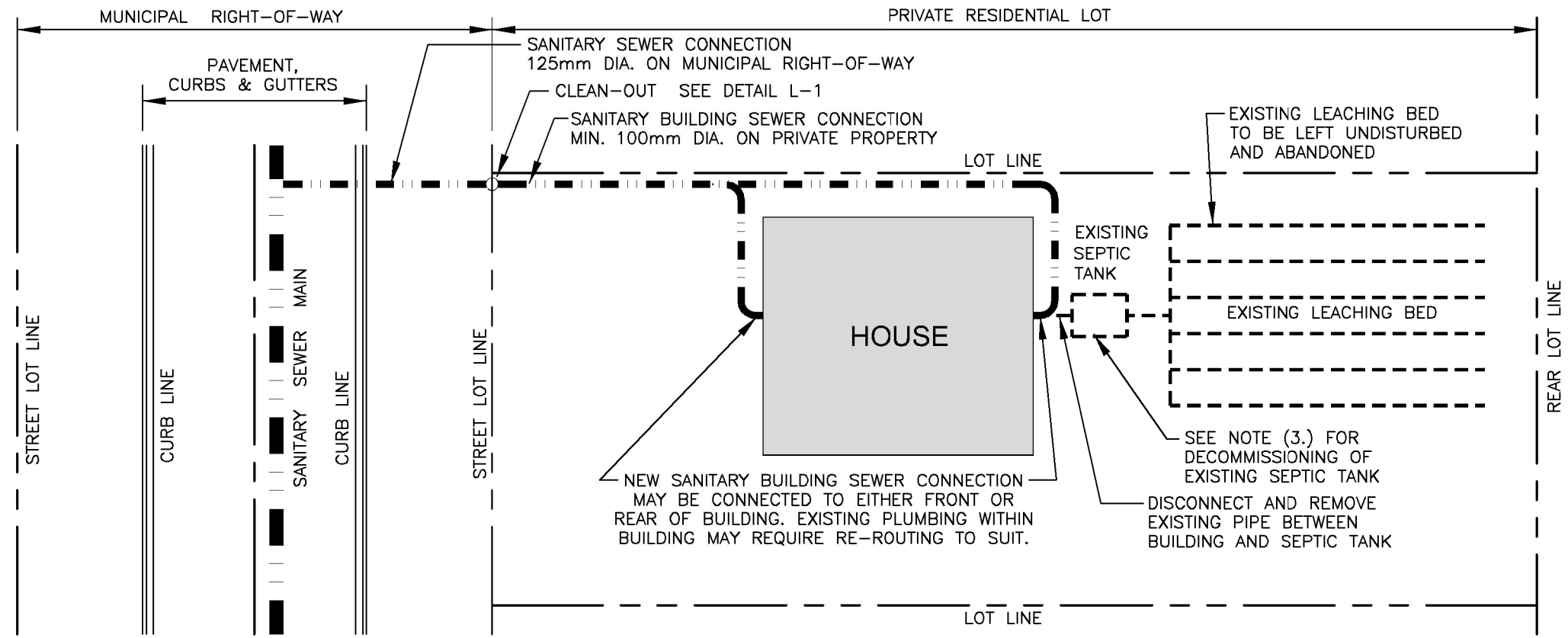

**PLAN VIEW**

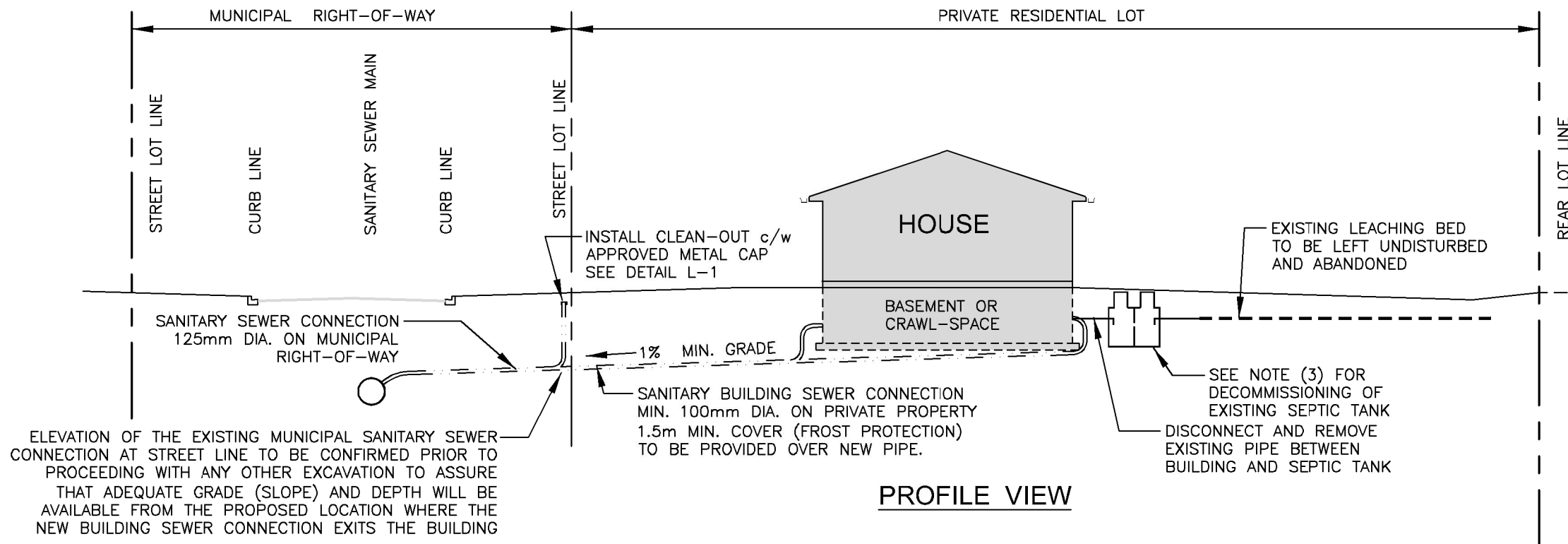

**PROFILE VIEW**

FILENAME: C:\PROJECTS\WORKING DIRECTORY\ACTIVE\337815\060175615-02-PC-COILING PLOTTED BY: STIRLING, TODD  
 PLOT DATE: 2018-04-02 @ 3:46:08 PM PLOT SCALE: 1:1 PLOT STYLE: DULON-STANDARD.CTB



No.	1	March 06, 2018
		Revision Date

Municipality of Chatham-Kent Development Manual

**Figure L-9**  
 CONNECTION OF AN EXISTING BUILDING LOT TO  
 A NEW MUNICIPAL SANITARY SEWER SYSTEM &  
 DECOMMISSIONING OF EXISTING SEPTIC SYSTEM



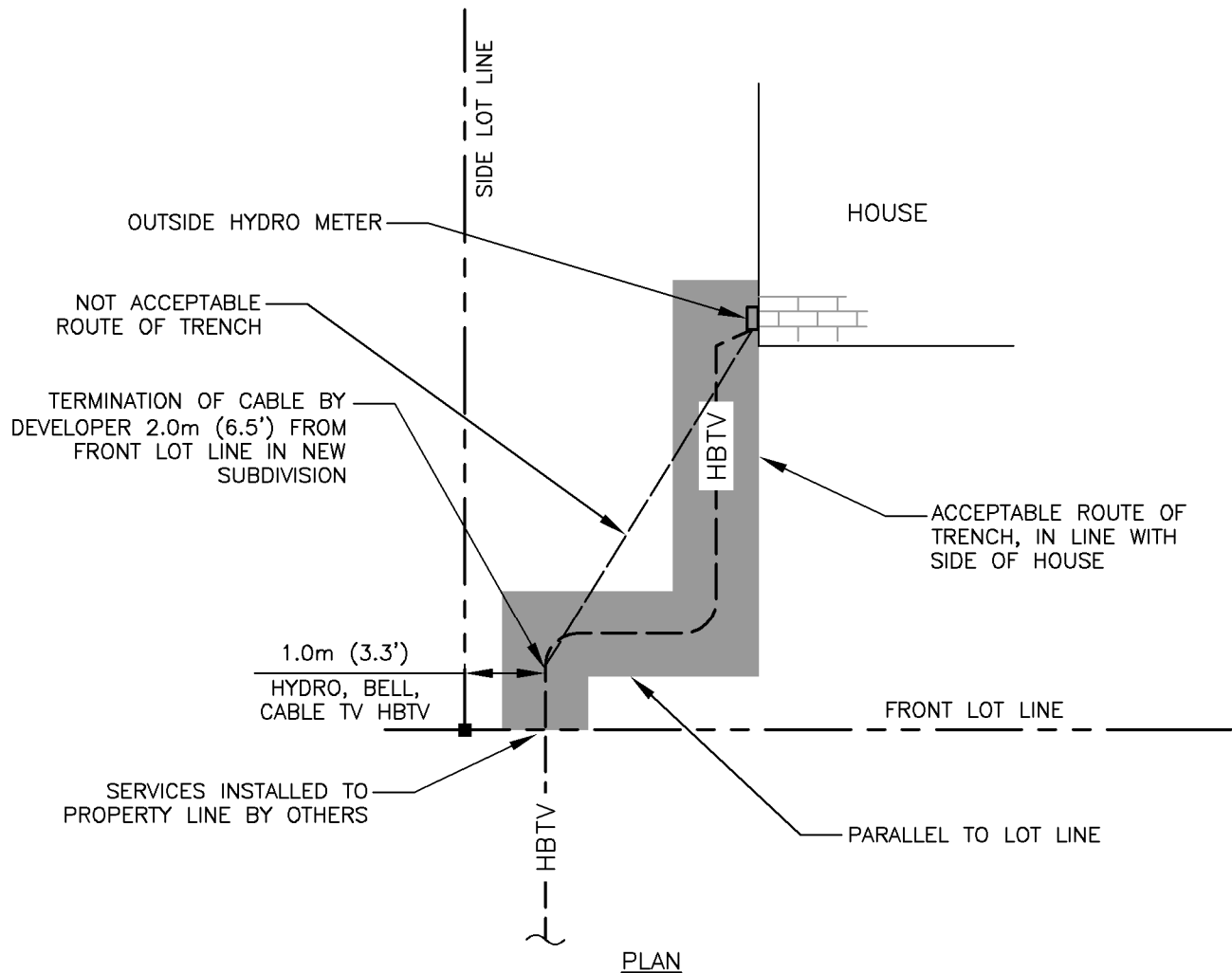

**NOTE:**

1. OBTAIN APPROVAL FROM ENTEGRUS/HYDRO ONE OFFICE FOR METER LOCATION ON HOUSE.
2. DO NOT BURY BIG 'O' CONDUIT UNTIL AFTER HYDRO CABLE INSTALLATION AND AFTER INSPECTION BY ENTEGRUS/HYDRO ONE.

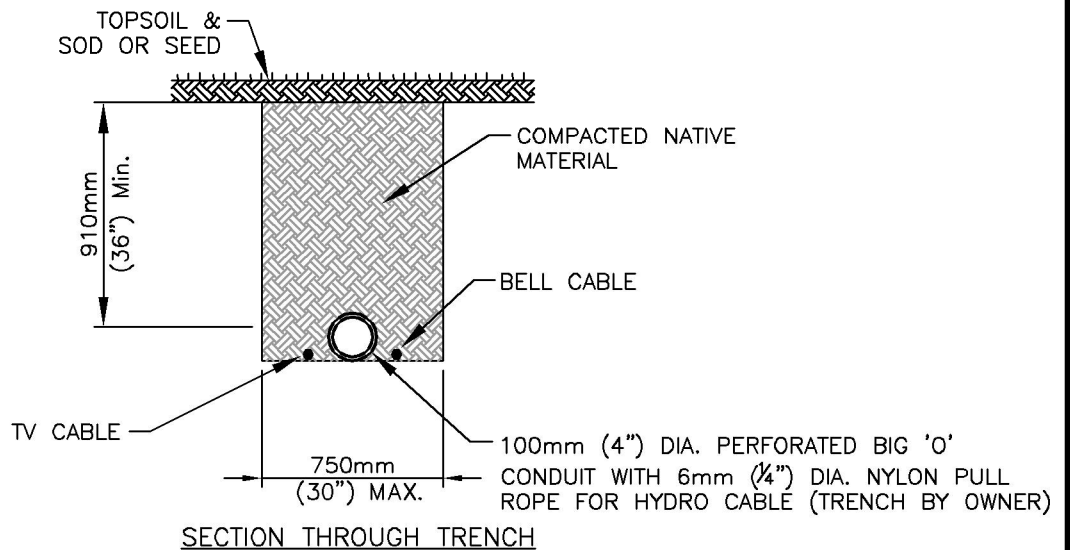

FILENAME: C:\PROJECTS\WORKING DIRECTORY\ACTIVE\XTRAS\DRS01560\175415-02-PC-COM-DMG PLOTTED BY: STIRLING, TODD  
 PLOT DATE: 2018-04-02 @ 3:46:11 PM PLOT SCALE: 1:1 PLOT STYLE: DILLON-STANDARD.DWT

1	March 06, 2018
No.	Revision Date

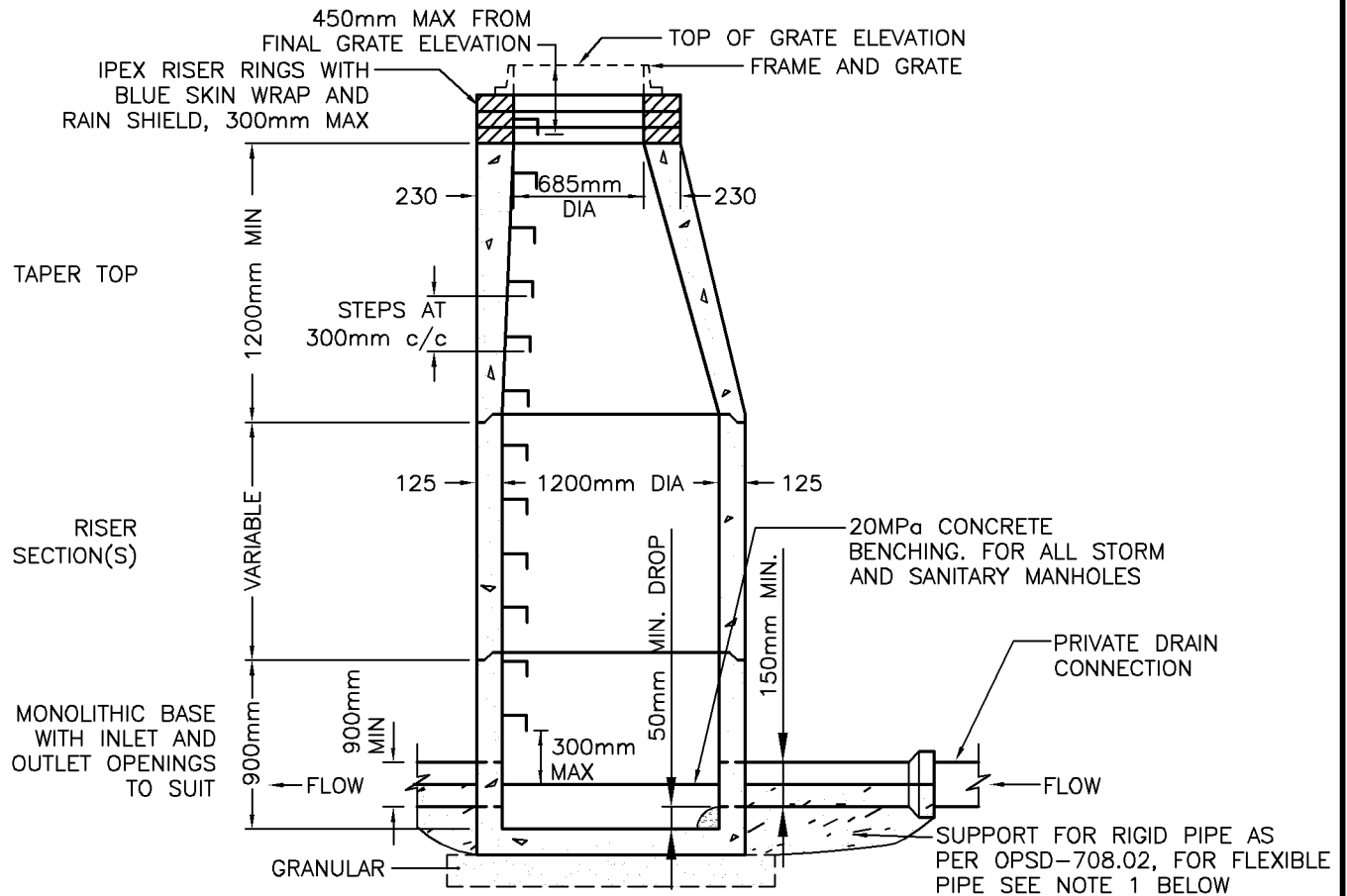

BOTTOM RISER SECTION WITH INLET AND OUTLET OPENINGS TO SUIT

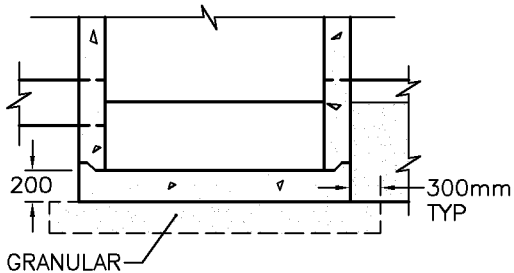

TYPE A  
PRECAST SLAB BASE

ALTERNATIVES

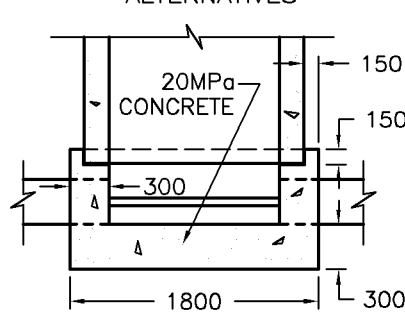

TYPE B  
CAST IN PLACE BASE

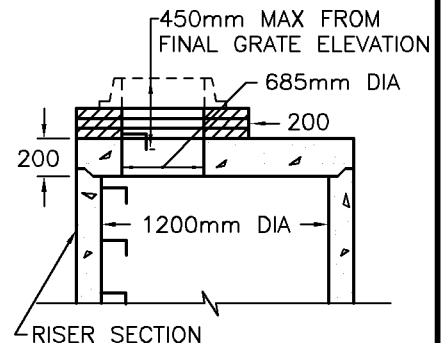

RISER SECTION  
TYPE C  
PRECAST FLAT TOP

FLEXIBLE JOINT 300mm MAX. FROM MANHOLE WALL, IN LIEU OF CONCRETE CRADLE.

TYPE D

APPROVED FLEXIBLE WATERTIGHT PIPE CONNECTOR IN MH OPENING IN LIEU OF CONCRETE CRADLE.

TYPE E

PIPE SUPPORT AT MANHOLE

**NOTES:**

- FOR FLEXIBLE PIPE USE TYPES 'D' OR 'E' PIPE SUPPORT ONLY.
- GRANULAR BACKFILL TO BE PLACED TO A MINIMUM THICKNESS OF 300mm ALL AROUND.
- SPECIAL BASE DESIGN REQUIRED FOR DEPTHS GREATER THAN 10.0m.
- FILL LIFTING HOLES AND PIPE CONNECTIONS AND PARGE ADJUSTMENT UNITS ON OUTSIDE 15mm THICK WITH 1:3 NON-SHRINK MORTAR MIX.
- PRECAST CONCRETE COMPONENTS AS PER OPSD-701.03.
- USE ALTERNATIVE BASE, TOP, PIPE SUPPORT OR CONNECTOR, STEPS, FRAME AND COVER AND/OR BENCHING WHERE SPECIFIED.
- STRUCTURES EXCEEDING 5.0m IN DEPTH TO INCLUDE SAFETY GRATE AS PER OPSD-404.02.
- ALL DIMENSIONS ARE IN MILLIMETRES UNLESS OTHERWISE SHOWN.

FILENAME: C:\PROJECTS\WORKING DIRECTORY\CHATHAM-KENT\STDS\0601860\175616-02-FIG-CONDUIT PLOTTED BY: STIRLING, TODD  
 PLOT DATE: 2018-04-02 @ 3:46:16 PM PLOT SCALE: 1:1 PLOT STYLE: DILLON-STANDARD.CTB

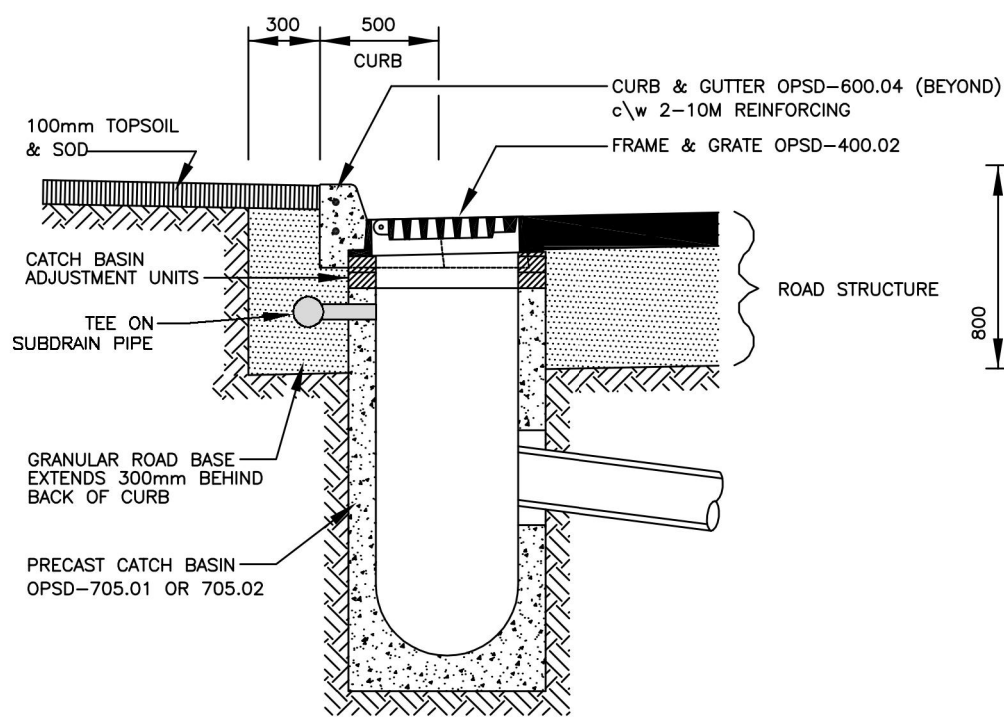

SECTION "A" - "A"

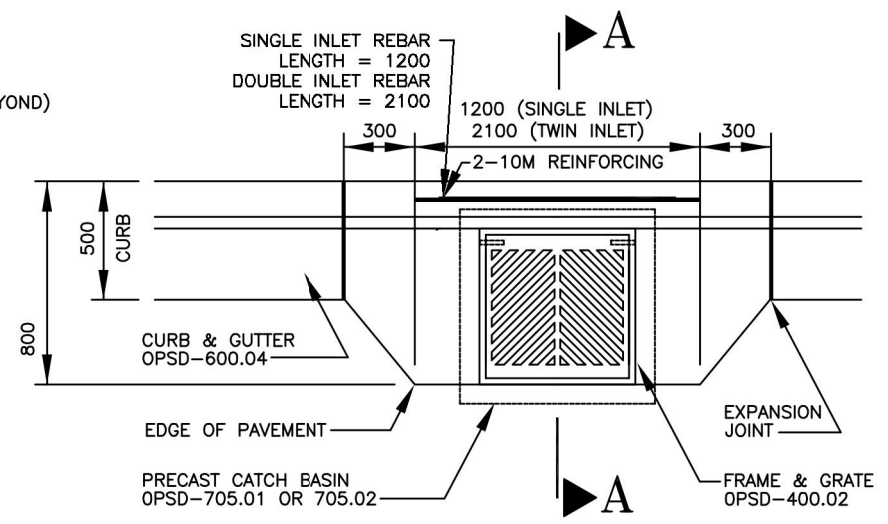

PLAN VIEW

**NOTE:**  
 PREFERENCE IS TO USE INLET CATCH BASIN. STANDARD CATCHBASIN IS ONLY TO BE USED WHERE THERE ARE CONFLICTS WITH EXISTING INFRASTRUCTURE AND A CURB INLET CATCHBASIN CAN NOT BE USED.



1	March 06, 2018
No.	Revision Date

Municipality of Chatham-Kent Development Manual

**Figure S-2**  
 STANDARD CATCH BASIN BOX-OUT



FILENAME: C:\PROJECTS\WORKING DIRECTORY\ACTIVE\30185\0801860\175616-02-FIB-CONVING PLOTTED BY: STIRLING, 1000  
 PLOT DATE: 2018-04-02 @ 3:46:20 PM PLOT SCALE: 1:1 PLOT STYLE: DILLON-STANDARD.CTB

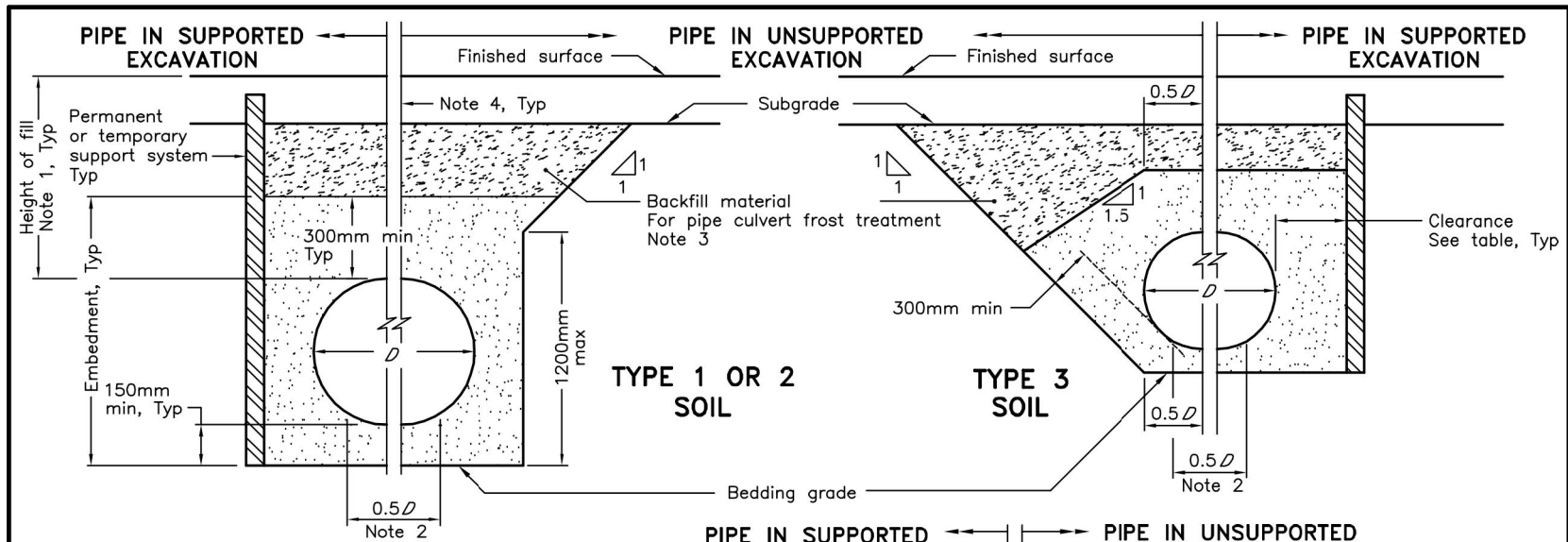

**LEGEND:**

$D$  - Inside diameter

**NOTES:**

- 1 Height of fill is measured from the finished surface to top of pipe.
- 2 The pipe bed shall be compacted and shaped to receive the bottom of the pipe.
- 3 Pipe culvert frost treatment shall be according to OPSD 803.030 and 803.031.
- 4 Condition of excavation is symmetrical about centreline of pipe.

A Granular material placed in the haunch area shall be compacted prior to placing and compacting the remainder of the embedment material.

B Soil types as defined in the Occupational Health and Safety Act and Regulations for Construction Projects.

C All dimensions are in metres unless otherwise shown.

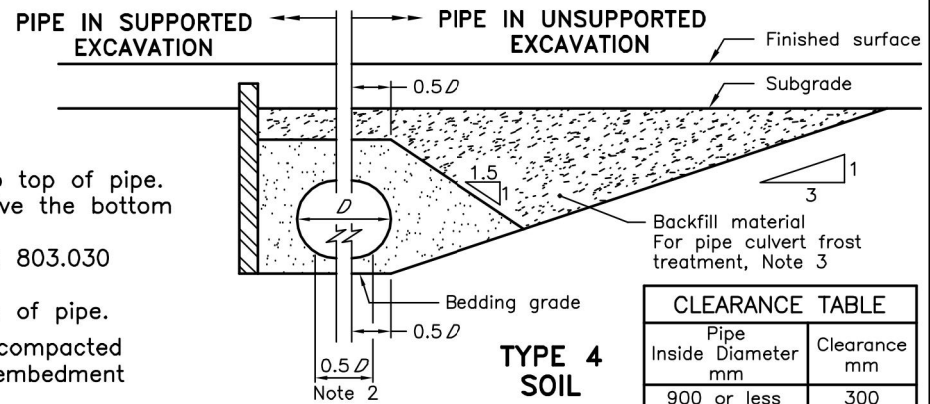

CLEARANCE TABLE	
Pipe Inside Diameter mm	Clearance mm
900 or less	300
Over 900	500

ONTARIO PROVINCIAL STANDARD DRAWING		Nov 2014	Rev 3
<b>FLEXIBLE PIPE                  EMBEDMENT AND BACKFILL                  EARTH EXCAVATION</b>			
		<b>OPSD 802.010</b>	



1	March 06, 2018
No.	Revision Date

Municipality of Chatham-Kent Development Manual

**Figure S-4**  
 FLEXIBLE PIPE EMBEDMENT AND  
 BACKFILL EARTH EXCAVATION - OPSD 802.010





ADJUSTMENT UNITS:  
MIN. OF ONE MAX. OF  
THREE, 300mm MAX

MAINTENANCE HOLE, CAST IRON  
COVER AND SQUARE FRAME  
OPSD 401.01 TO BE SET ON  
FULL BED OF MORTAR

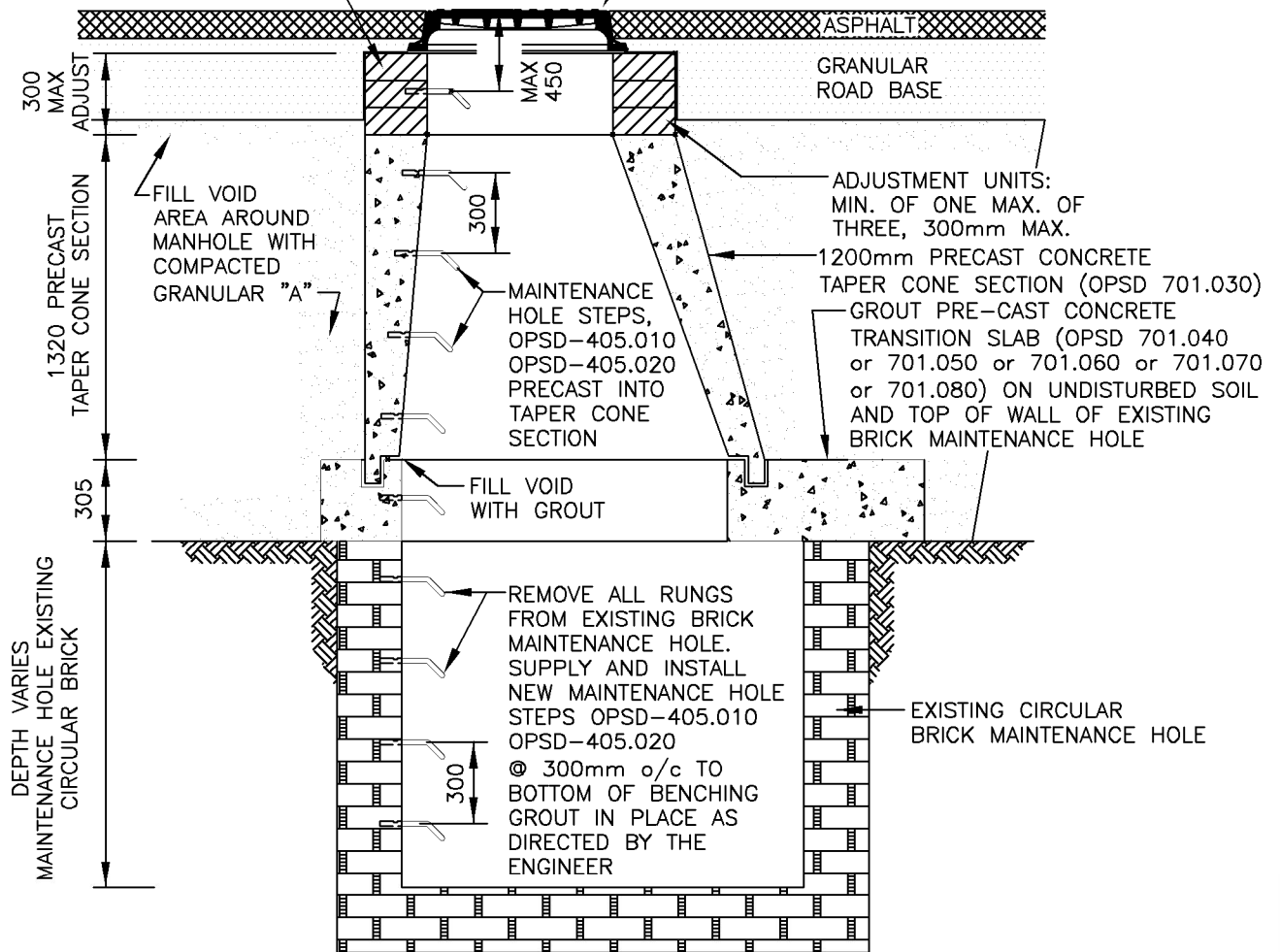

FILENAME: C:\PROJECTS\WORKING DIRECTORY\ACTIVE\3\TMS\05601560\175415-02-PC-COM.DWG PLOTTED BY: STIRLING, TODD  
PLOT DATE: 2018-04-02 @ 3:46:28 PM PLOT SCALE: 1:1 PLOT STYLE: DILLON-STANDARD.DTB

1	March 06, 2018
No.	Revision Date